

Ordinance No. 25-744
Exhibit "A"

CITY OF BRIDGEPORT

DOUGLAS COUNTY

WASHINGTON



CONSTRUCTION STANDARDS

MAY 2025



Gray & Osborne, Inc.
CONSULTING ENGINEERS

CITY OF BRIDGEPORT
CONSTRUCTION STANDARDS
Updated 2025

MATERIALS AND METHODS OF CONSTRUCTION

PART 1	STORM
PART 2	WATER
PART 3	SEWER
PART 4	STREET

STANDARD DETAILS

STORM

SD-1	Storm Drain Trench Section
SD-2	Catch Basin Type 1
SD-3	Catch Basin Type 1A
SD-4	Catch Basin Type 2
SD-5	Concrete Drywell Manhole
SD-6	Infiltration Trench
SD-7	Infiltration Chamber

WATER

W-1	Water Main Trench Section
W-2	Thrust Blocks
W-3	Vertical Anchor Block
W-4	Typical Valve Installation
W-5	Valve Stem Extension
W-6	Valve Marker
W-7	Fire Hydrant Assembly

- W-8 3/4" or 1" Water Service
- W-9 1-1/2" or 2" Water Service
- W-10 Blow Off Assembly
- W-11 1" Air and Vacuum Release Assembly

SEWER

- SS-1 Typical Trench Section
- SS-2 Standard 48" Manhole
- SS-3 Manhole Plan View
- SS-4 Saddle Manhole
- SS-5 Shallow Manhole
- SS-6 Standard Manhole Frame and Cover
- SS-7 Manhole Step
- SS-8 Connection to Existing Manhole
- SS-9 Standard Side Sewer
- SS-10 Sanitary Sewer Cleanout

STREET

- ST-1 Typical Roadway Section
- ST-2 Alternate Roadway Section
- ST-3 Typical Concrete Sidewalk
- ST-4 Typical Curb and Gutter
- ST-5 Concrete Driveway Entrance
- ST-6 Sidewalk Ramps
- ST-7 Detectable Warning Surface
- ST-8 Typical Utility Crossing
- ST-9 Typical CMU Wall Details

MATERIALS AND METHODS OF CONSTRUCTION

SD-1 STORM DRAIN PIPING

Storm Drain pipe shall be corrugated polyethylene pipe (CPEP) or polyvinyl chloride (PVC) unless specifically noted otherwise.

All materials delivered to the job site shall be new, free from defects, and marked to identify the material, class, and other appropriate data such as thickness for piping.

Acceptance of materials shall be subject to strength and quality testing in addition to inspection of the complete product. Acceptance of installed piping systems shall be based on inspection and leakage tests.

All types of pipe shall be handled in a manner that will prevent damage to the pipe.

Dirt or other foreign material shall be prevented from entering the pipe or pipe joint during handling or laying operations, and any pipe or fitting that has been installed with dirt or foreign material in it shall be removed, cleaned, and relayed. A clean whiskbroom shall be used for this purpose and for brushing to remove foreign matter prior to joining of pipe ends. At times when pipe laying is not in progress, the open ends of the pipe shall be closed by a watertight plug or by other means approved by the Owner to ensure cleanliness inside the pipe.

Pipe shall be stacked in such a manner as to prevent damage to the pipe, to prevent dirt and debris from entering the pipe, and to prevent any movement of the pipe. The bottom tiers of the stack shall be kept off the ground on timbers, rails, or other similar supports.

All bell and spigot connections shall be made up in strict compliance with the manufacturer's recommendations and all sewer pipe manufacture and handling shall meet or exceed the ASTM and SPAW recommended specifications.

Pipe handling after the gasket has been affixed shall be carefully controlled to avoid disturbing the gasket and knocking it out of position, or loading it with dirt or other foreign material. Any gaskets so disturbed shall be removed, cleaned, re-lubricated if required, and replaced before the rejoining is attempted.

Care shall be taken to properly align the pipe before joints are entirely forced home. During insertion of the tongue or spigot, the pipe shall be partially supported by hand, sling or crane to minimize unequal lateral pressure on the gasket and to maintain concentricity until the gasket is properly positioned. Since most flexible gasketed joints tend to creep apart when the end pipe is deflected and straightened, such movement shall be held to a minimum once the joint is home.

Sufficient pressure shall be applied in making the joint to assure that it is home, as described in the installation instruction provided by the pipe manufacturer. Sufficient restraint shall be applied to the line to assure that joints once home are held so, until fill material under and alongside the pipe has been sufficiently compacted.

A. CPEP Pipe and Fittings

Corrugated polyethylene pipe (CPEP) and fittings shall conform to the requirements of AASHTO M-252 and AASHTO M-294, Type S. Fittings shall be as shown on the Plans and as required to provide a complete piping system and meet the same requirements as the CPEP.

B. PVC Pipe and Fittings

Solid wall PVC storm sewer pipe and fittings shall comply with ASTM D3034, SDR 35 for pipe sizes up to 15 inches. Solid wall PVC storm sewer pipe and fittings shall comply with ASTM F 679 using a minimum pipe stiffness of 46 psi in accordance with Table 1 for pipe sizes from 18 inches to 48 inches. Pipe and fittings shall be furnished with bells and spigots, which are integral with the pipe wall and with a rubber gasket securely locked in place in the bell. Pipe joints shall conform to ASTM D3212 using flexible elastomeric gaskets conforming to ASTM F477.

C. Flexible Couplings

Flexible couplings shall be Calder-type where specifically indicated on the Plans. Calder-type flexible couplings shall consist of all elastomeric PVC sleeve secured to the pipes with stainless steel clamping bands. Adapter couplings shall be furnished for transitions between piping of different outside diameters as necessary.

Calder-type flexible couplings shall be as manufactured by Calder Co., Fernco, or equal.

SD-2 CATCH BASINS

Precast components shall conform to the requirements of ASTM C478. All Portland cement used in the manufacture of the precast sections shall conform to the requirements of ASTM C150 and shall be Type II or Type V.

Thickness of a Type 1 catch basin shall be 4 inches minimum and reinforced with welded wire fabric having a minimum area of 0.12 square inches per foot. Welded wire fabric shall comply with ASTM A497. "Knockouts" shall be free of

welded wire fabric and provided on four sides to accommodate the pipe size, invert elevations, and direction as shown on the Plans.

Standard precast riser sections shall consist of rectangular sections to accommodate a Type 1 catch basin. Reinforcement shall be in accordance with ASTM C497. Minimum height of a riser section shall be 6 inches. The height of riser and base sections shall be arranged so no pipes pass through the joining surfaces.

Precast base sections for Type 2 catch basins shall conform to the requirements for precast riser sections. The base shall be a minimum of 6-inches thick underneath the pipe invert.

Standard precast riser sections shall consist of circular sections in standard nominal inside diameter as shown on the Plans. Reinforcement shall be in accordance with ASTM C478. Minimum height of a riser section shall be 1 foot. The height of riser and base sections shall be arranged so no pipes pass through the joining surfaces.

Openings for pipe shall be circular, tapered toward the inside of the section, and shall be of the minimum size possible to accommodate the size of pipe to be inserted and to effectively seal the joint.

Catch basin installation shall be as shown on the Plans. Precast sections with damaged joint surfaces or with cracks or damage that would permit infiltration shall not be installed.

Precast base sections shall be set on a prepared bedding material. Before the precast base is set, the gravel shall be carefully leveled to provide full bearing for the entire base slab.

The frame shall be set carefully to the established surface grade in a full bed of cement grout. The catch basin rim elevation shall be set flush with the pavement or improved areas.

SD-2 MANHOLES

Precast components shall conform to the requirements of ASTM C478. All Portland cement used in the manufacture of the precast sections shall conform to the requirements of ASTM C150 and shall be Type II or Type V.

Precast base sections shall conform to the requirements for precast riser sections. The base shall be a minimum of 6-inches thick underneath the pipe invert. Openings for pipe shall be circular, tapered toward the inside of the

section, and shall be of the minimum size possible to accommodate the size of pipe to be inserted and to effectively seal the joint.

Standard precast riser sections shall consist of circular sections in standard nominal inside diameter as shown on the Plans. Reinforcement shall be in accordance with ASTM C478. Minimum height of a riser section shall be 1 foot. The height of riser and base sections shall be arranged so no pipes pass through the joining surfaces.

The taper section (cone) shall be eccentric, tapering to 24-inches inside diameter and shall be between 18-inches and 36-inches high. Joining to the riser sections shall be similar to joining between riser sections, but the top surface shall be flat and at least 5-inches wide, radially, to receive grade rings.

Grade rings above the taper section shall be 24-inches inside diameter and 4-inches high. Grade ring height shall be a minimum of 8 inches, with a maximum of 20 inches. Otherwise another section of manhole rings shall be installed.

Manhole installation shall be as shown on the Plans. Precast sections with damaged joint surfaces or with cracks or damage that would permit infiltration shall not be installed. Precast base sections shall be set on prepared bedding materials. Before the precast base is set in place, the bedding material shall be carefully leveled to provide full bearing for the entire base section.

Precast riser sections and cones shall be set using the specified joint sealant or gasket. Priming and preparation of surfaces and installation of jointing material shall be in strict conformance with the manufacturer's instructions. Only one 12-inch-high riser section shall be used per manhole and it shall be placed immediately below the cone. Grade rings shall be set in a full bed of cement grout.

All pipe connections to manholes shall be made with manhole adaptors.

Manhole frames shall be set carefully to the established surface grade in a full bed of cement grout. The manhole rim elevation shall be set flush with the existing pavement or grade in paved and improved areas. In unimproved areas, manhole rim elevations shall be set 2 inches above grade unless otherwise shown on the Plans to be set higher.

After placement, channel decks shall be given a light broom finish and shall be sloped to drain into the channels. Patch all lifters after removed picking eyes. Patch all joints inside and outside flush with walls.

Steps shall be installed in base sections, riser sections and tapered sections so that the completed manhole will have a continuous vertical ladder with equally spaced rungs as shown on the Plans. Steps shall be firmly cast or grouted in place. Infiltration from or around steps will not be permitted.

Pipe connections to existing manholes or vaults shall be in accordance with Section 7-05.3(3) of the WSDOT Standard Specifications and as further shown on the Plans.

SD-3 PRECAST CONCRETE DRYWELLS

Precast components shall conform to the requirements of ASTM C478. All Portland cement used in the manufacture of the precast sections shall conform to the requirements of ASTM C150 and shall be Type II or Type V.

Precast base sections shall conform to the requirements for precast riser sections. The base shall be a minimum of 6-inches thick underneath the pipe invert. Openings for pipe shall be circular, tapered toward the inside of the section, and shall be of the minimum size possible to accommodate the size of pipe to be inserted and to effectively seal the joint.

Standard precast riser sections shall consist of circular sections in standard nominal inside diameter as shown on the Plans. Reinforcement shall be in accordance with ASTM C478. Minimum height of a riser section shall be 1 foot. The height of riser and base sections shall be arranged so no pipes pass through the joining surfaces.

The taper section (cone) shall be eccentric, tapering to 24-inches inside diameter and shall be between 24-inches and 36-inches high.

Grade rings above the taper section shall be 24-inches inside diameter and 4-inches high. Grade ring height shall be a minimum of 8 inches, with a maximum of 20 inches. Otherwise another section of manhole rings shall be installed.

Seepage port size and shape may vary per manufacturer. Each seepage port shall provide a minimum of 1-square inch and a maximum of 7-square inches for round openings and 15-square inch for rectangular openings. The ports shall be uniformly spaced with at least one port per 8 inches of drywell height and 15 inches per drywell circumference.

The dry well shall be surrounded by a geo-fabric lining and drain rock per the standard detail. A settling catch basin shall be installed upstream of the drywell to settle out solids prior to entering the drywell.

SD-4 RINGS AND COVERS

Castings for manhole rings shall be gray-iron conforming to the requirements of ASTM A48/AASHTO M105, Grade 30B. Covers shall be ductile iron conforming to ASTM A536, Grade 80-55-06. All rings and covers shall be of uniform quality, free from blowholes, porosity, shrinkage, distortion, cracks, or other defects. Repair of defects shall not be permitted. All mating surfaces shall be machined finished to ensure a non-rocking fit. All covers shall be interchangeable within the dimensions as shown on the Plans and marked "sewer," "drain," or "water" as appropriate. Locking/tamperproof covers shall be secured to the ring with three 5/8-inch stainless steel Allen head cap screws. When watertight covers are required the locking style ring and covers shall be used and include a machined groove in the seat of the ring or underside of the cover and a gasket installed to assure a watertight seal. Covers shall be without pickholes. The manufacturer's identification shall be cast with a minimum of 1/2-inch letters on exposed surfaces. Manhole rings and covers shall have a design wheel load conforming to AASHTO/ASTM A16 design loading HS20-44.

The frames and covers shall be made by Olympic Foundry, Inc., D&L Foundry, East Jordan Iron Works, or Neenah.

SD-5 STEPS

Polypropylene manhole steps shall be made of a copolymer polypropylene, superior in its resistance to corrosion, meeting the requirements of ASTM 2146 Type II, Grade 16906, and shall completely encapsulate a deformed 1/2-inch steel reinforcing rod conforming to ASTM A615, Grade 60. Polypropylene steps shall be factory installed in complete accordance with the manufacturer's instructions. This shall be accomplished by predrilling two parallel 1-inch holes, 3-3/4-inch deep, and 13-inches on center in the cured concrete base, riser, and taper sections of the manhole. The insertion ends of the step shall be fully coated with non-shrink epoxy grout then driven into the holes to the prescribed depth. In no case will the predrilled hole be allowed to penetrate through the wall of the manhole section.

Steps shall be Lane International Corporation Manhole Step or equal.

SD-6 FRAMES AND GRATES

Castings for catch basin and inlet frames shall be gray-iron conforming to the requirements of ASTM A48/AASHTO M105, Grade 30B. Grates or solid covers shall be ductile iron conforming to ASTM A536, Grade 80-55-06. All frames and grates or covers shall be of uniform quality, free from blowholes, porosity, shrinkage, distortion, cracks, or other defects. Repair of defects shall not be permitted. All mating surfaces shall be seated properly to prevent rocking of the

grate/cover. The frames, grates, and covers shall have a design wheel load conforming to AASHTO/ASTM A16 design loading HS20-44.

The frames and grates/covers shall be made by East Jordan Iron Works, Olympic Foundry, Inc., D&L Foundry, or Neenah.

SD-7 BEE-HIVE FRAME

The beehive frame shall be standard galvanized steel constructed from 3/4-inch smooth round bars and 3/4-inch- by 4-inch-wide bands. The upper opening shall be 2 feet in diameter and the vertical bars shall be at 45-degree angles.

SD-8 GASKETS AND MANHOLE ADAPTERS

Rubber gaskets shall conform to Section 9-04.4 of the WSDOT Standard Specifications. Pipe connections to existing manholes shall be made using a heavy-duty sand collar with gasket, head, or equal. Pipe connections to new manholes or vaults shall utilize an adaptor coupling with gasket or watertight flexible rubber boot, Kor-n-Seal or equal. The Contractor shall provide Kor-n-Seal cavity O-rings to fill the annular spaces between the pipe and the manhole or vault wall.

SD-9 INFILTRATION TRENCH

Infiltration trench will be shall be installed at the approval of the city. The pipe used shall be perforated CPEP. The pipe shall be surrounded with a clean drain rock and the trench shall be wrapped with non-woven geotextile per the standard detail.

SD-10 INFILTRATION CHAMBER

Infiltration chambers shall be installed at the approval of the city. The chambers shall be surrounded with clean crushed drain rock and wrapped with non-woven geotextile per the standard detail. The infiltration chamber shall include an inspection port as shown on the standard detail.

S-10 TELEVISED INSPECTION

The Developer shall perform a complete televised inspection of the storm pipe and appurtenances and shall provide to the City, a 1/2-inch VHS colored audio-visual tape recording, DVD or CD of the inspections together with a written log of the television inspection. The camera shall be a pan and tilt type equipped with adequate light and focusing to allow inspection of storm main and full

circumference inspection of main line joints and fittings. The City shall determine if the quality of the tape is acceptable.

The City shall be notified 48 hours prior to any television inspection and this work shall be performed on a schedule to allow the City to witness the inspection.

If the television inspection shows indications of deflections in the pipe, the City may require that the Developer pull a proper sized mandrel for the main through the pipe to confirm that the pipe deflection does not exceed the manufacturer's recommendations.

Any defects in material or installation identified by the television inspection shall be repaired as required by the City at the Developer's expense.

END PART 1

W-1 WATER MAIN PIPE

Water mains to be installed shall be polyvinyl chloride (PVC) for all sizes, unless specifically noted otherwise.

The PVC pipe shall conform to AWWA C900 or AWWA C905 Standards. The PVC pipe shall have the same outside dimensions as ductile iron pipe and shall be a minimum of SDR 18.

The pipe manufacturer shall certify in writing that the inspection and all tests of the specified standards for both pipe and gaskets being supplied for this project have been made and that the results thereof comply with the requirements of the Standard.

Joints shall be "made-up" in accordance with the manufacturer's recommendations. Standard joint material, including rubber ring gaskets shall be furnished with the pipe. Materials shall be suitable for the specified pipe sizes and pressures.

Except where necessary, in making connections with other lines and unless authorized by the City, pipes shall be laid with bells facing in the direction of laying and for lines on an appreciable slope, the bells shall face upwards.

All pipe shall be delivered to the job site with water tight wrapping or pipe plugs. All pipe shall be carefully checked on delivery as well as before placing in the trench. Pipe shall be carefully bedded, joined and protected. It shall be laid to the line and grade established and at all times the interior kept free from dirt, gravel, and all other foreign matter. The open ends shall be wrapped or plugged and secured at any time pipe laying is not in progress.

Water mains shall be laid on a uniform grade and the Developer shall anticipate those places where additional depth is required to avoid certain utilities, and adjust the pipeline profile accordingly to maintain uniform grade.

Prior to making permanent connections to the existing system, the new water main including service lines shall have passed a pressure test, been adequately flushed, and finally passed the required bacteriological test.

Dirt or other foreign material shall be prevented from entering the pipe or pipe joint during handling or laying operations, and any pipe or fitting that has been installed with dirt or foreign material in it shall be removed, cleaned, and relayed. A clean whiskbroom shall be used for this purpose and for brushing to remove foreign matter prior to joining of pipe ends. At times when pipe laying is not in progress, the open ends of the pipe shall be closed by a watertight plug or by other means approved by the City to ensure cleanliness inside the pipe.

Pipe shall be stacked in such a manner as to prevent damage to the pipe, to prevent dirt and debris from entering the pipe, and to prevent any movement of the pipe. The bottom tiers of the stack shall be kept off the ground on timbers, rails or other similar supports. Pipe on succeeding tiers shall be alternated by bell and plain end. Timbers 4 inches by 4 inches in size shall be placed between tiers and chocks shall be placed at each end to prevent movement. For safety each size of pipe shall be stacked separately.

W-2 WATER MAIN FITTINGS

All fittings shall be short-bodied, ductile iron complying with applicable AWWA C110 or C153 Standards. All fittings shall be cement-lined and either mechanical joint or flanged, as indicated on the Plans.

Fittings in sections shown on the Plans requiring restrained joints shall be mechanical joint fittings with a mechanical joint restraint device. The mechanical joint restraint device shall have a working pressure of at least 250 psi with a minimum safety factor of 2:1 and shall be EBAA Iron, Inc. MEGALUG, Romac Industries, Inc., Grip Ring Pipe Restrainer or approved equal. Stargrip Series 3000 mechanical joint restraint devices are not accepted or approved as equal.

Fittings shall be adequately "blocked" with poured-in-place concrete, within wooden forms shaped to establish a firm minimum bearing area, against an undisturbed earth wall as shown on the Standard Details. 4" x 4" minimum size Timber blocking may be permitted as temporary blocking, when utilized as forms outside the poured-in-place concrete when fittings are to be pressurized prior to the 24 hour minimum "set" time. The concrete thrust blocks must be in place at least 24 hours before beginning the pressure test, to allow the concrete to "set". The strength of the concrete shall be 2,000 psi minimum.

All valves and all fittings requiring a concrete block shall first be covered with 20-pound tarpaper, before concrete is poured. The concrete shall not cover joints, bolt heads or nuts.

All bolts shall be coated with Armite Anti-Seize Compound No. 609, or equal, prior to installation.

Before cutting existing pipes, the Developer shall measure the pipe outside diameter to determine if pipe was manufactured to a diameter which is different than presently specified in AWWA Standards, and if required, the Developer shall furnish alternate or additional fittings more compatible with the pipe outside diameter.

All connections to other pipe shall be with Romac, Smith-Blair, Dresser or Ford flexible couplings. The couplings shall have long middle rings and shall have a fusion-bonded epoxy coating. Coupling gaskets shall be Grade 60. The bolts and nuts shall be high strength, low alloy steel or electro-galvanized mild steel.

All joints in the pipe, fittings, valves, flexible couplings, and sleeves, shall be fully seated with small clearances allowed for pipe expansion. Where flexible couplings and sleeves are called for, the space between pipe ends shall not exceed 1/4 inch.

When the space between pipe ends is excessive, a short section of pipe may be inserted as a spacer ring to limit such pipe movement within the coupling or sleeve, to obtain the 1/4-inch limitation stipulated herein.

W-3 VALVES

All valves 12 inch and smaller shall be resilient seated ductile iron gate valves except where shown on the Plans. All valves 16 inch and larger shall be ductile iron butterfly valves.

The valve manufacturer shall certify in writing that the inspection and all tests of the specified standards for the valves being supplied for this project have been made and that the results thereof comply with the requirements of the Standard.

A. Resilient-Seated Gate Valves

The gate valves shall be resilient seated ductile iron body valves with non-rising stems (NRS) opening counterclockwise and equipped with a 2-inch square operating nut. Valves shall meet the full requirements of the AWWA C509 or C515 Standards. The valves shall have double "O" ring stem seals which shall withstand the test pressure without leakage. Valves shall be rated at 250 pounds per square inch (psi), minimum working pressure and furnished with either flanged and/or mechanical joints as shown on the Plans. All surfaces, interior and exterior, shall be epoxy-coated, acceptable for potable water.

Valves shall be Mueller, M&H, Clow, American Flow Control Series 2500, U.S. Pipe or approved equal.

B. Butterfly Valves

The butterfly valves shall be either mechanical joint or flanged ductile iron body valves equipped with a 2-inch square operating nut and shall be of the tight closing, rubber seat type. Valves shall meet the full requirements of AWWA C504-87 Standards, Class 150-B except the valve shall be able to withstand 200 psi differential pressure without leakage.

Butterfly valves shall be Henry Pratt Company "Groundhog," "Dresser 450," or approved equal.

All valves shall be set with the operating stems vertical. The axis of the valve box shall be common with the projected axis of the valve operating stem. The tops of the adjustable valve boxes shall be set to the existing or established grade, whichever is applicable.

Valves shall include operator extension stems to bring the operating nut from 2'-0" to 1'-6" from finished grade.

The extension stem of the length required to meet field conditions shall be a manufactured unit with a 1-inch-diameter mild steel rod. At the top of the extension stem there shall be a 2-inch standard operating nut complete with a centering flange.

Valve boxes shall be equal to the "Rich 940" Model or Sather Manufacture. The flared end of the valve box shall be set at the bottom elevation of the 2-inch operating nut to allow space for rocks to be moved laterally from the operation nut. The "ears" on the valve box top shall be aligned parallel in the direction of the branch the valve opens and closes.

The valve box shall be placed over the valve or valve operator in such a manner that the valve box does not transmit shock or stress loads to the valve. The casting shall not rest directly upon the body of the valve or upon the water main.

Any extension of the valve box shall utilize additional flared end valve box bottom sections or cast iron hub soil pipe. Other materials are not acceptable.

In areas where the valve box is not in concrete or asphalt a 24-inch-diameter by 6-inch cement concrete block shall be installed around the valve box at finished grade. The valve box shall be flush with the top and centered.

A fiberglass valve marker post shall be furnished and installed where directed. Valve marker posts shall be blue in color, 3.75-inches wide (flat), 60-inches long and furnished with a 3-inch- by 3-inch-high density white reflector (250 candle power) and a flexible anchor barb. Valve markers shall be Carsonite Utility Marker CUM 375.

Markers shall be placed at the edge of the right-of-way opposite the valve and set so as to leave 36 inches of the post exposed above grade. The size of the valve and the distance in feet and inches to the valve shall be noted with decals, typically designed for use on fiberglass boats, placed on the face of the post, using letters approximately 2-inches high. Each post shall include the following

decal: "Caution Water Valve, Before Digging, Call 1-800-424-5555, Utility Underground Location Center."

W-4 TAPPING TEES AND TAPPING VALVES

The tapping sleeves shall be rated for a working pressure of 250 psi minimum and furnished complete with joint accessories. Tapping sleeves shall be constructed in two sections for ease of installation and shall be assembled around the main without interrupting service.

Fabricated steel style sleeves shall be fusion bonded coated, acceptable for potable water, and shall be manufactured by JCM, Romac or approved equal.

Size on size connections shall utilize stainless steel full circle tapping tee or DI MJ cut-in tee.

Tapping valves shall be resilient-seated ductile iron body gate valves provided with a standard mechanical joint outlet for use with ductile iron pipe and shall have oversized seat rings to permit entry of the tapping machine cutters. In all other respects, the tapping valves shall conform to the resilient seat gate valves herein specified with regards to operation and materials.

The tapping sleeve and valve shall be pressure tested to 200 psi (water) prior to tapping the main.

The installation of the tapping sleeves and valves and the tapping of the main shall be performed by Speer Taps, Superior Taps, or Approved by City.

W-5 AIR RELIEF VALVES

Air and vacuum release assemblies shall be installed at high points on the water system as shown on the Plans or designated in the field by the City.

The air relief assemblies shall be a combination air and vacuum valve APCO 143C or equal complete as shown on the Standard Detail.

W-6 BLOWOFF ASSEMBLIES

The blowoff assemblies shall be furnished and installed as shown on the Standard Detail.

Temporary blowoffs utilized by the Contractor for flushing the water main shall be sufficient size to obtain 2.5 feet per second velocity in the main.

W-7 FIRE HYDRANTS

The fire hydrants shall be the break-away compression type, meeting AWWA C502-85 Standards, in which the valve will remain closed if the barrel is broken. The hydrants shall have a barrel diameter of not less than 8-1/2 inches, and the main valve opening shall be not less than 5-1/4 inches in diameter. The fire hydrants shall be equipped with two, 2-1/2-inch National Standard Thread (NST) hose nozzles and one, 4-1/2-inch NST pumper port. A permanent anodized 5-inch Storz hydrant adapter and anodized Storz blind flange shall be installed on the 4-1/2-inch pumper port. Branch connection shall be for 6-inch pipe, as noted on the Standard Details, and shall be mechanical joint.

Fire hydrants shall be Mueller Centurian (A-423).

The Contractor shall furnish fire hydrants with the correct bury depth (trench depth), in accordance with the specified pipe depth and special conditions of the Project. The fire hydrants shall be installed to provide the mounting height above finished grade as shown on the Standard Detail. The hydrant shall be installed plumb on the vertical axis.

A 36-inch by 36-inch by 8-inch cement concrete block shall be installed with a broomed surface and finished edge at the finished grade line and shall be located 2 inches below the bury line of the hydrant. One quarter inch expansion strips shall be placed between hydrant barrel and concrete. Forms shall be removed from the block prior to acceptance by the City.

The hydrants shall be wire brushed, primed with one coat of Preservative All Metal Guard II and painted with two coats of Yellow to match the City's existing hydrants.

Between the time that the hydrant is installed and the completed facility is placed in operation, the hydrant shall at all times, be wrapped in burlap, bagged, or covered in some other suitable manner as approved by the City, to clearly indicate that the hydrant is not in service.

The resilient, seated ductile iron body gate valve shall have a flange by mechanical joint body, and be bolted to the main line tee.

The connecting pipe between the fire hydrant and gate valve shall be 6-inch PVC pipe and shall not exceed 50 feet in length. The fire hydrant and gate valve shall be restrained with a mechanical joint restraint device as indicated in Water Main Fittings. In addition to this, the hydrant and tee shall be fully blocked with concrete.

W-8 SERVICE CONNECTIONS

Individual services to each structure and/or property shall be installed and connected to the new water mains.

Upon completion of the installation of the water main (before testing and disinfection) services shall be installed by connecting to the water main and extending the service line to the property line as shown on the Standard Details or approved equal. Service lines for residential property shall be 1-inch HDPE with a minimum pressure rating of 200 psi. Larger service lines shall be of the type and style as designated in the Standard Details and shown on the Plans.

Two inch and smaller meters are supplied by the City. Three inch and larger meters fall into a different design criteria and will be specifically coordinated with the City.

Corporation stops and the single meter shut-off valves shall be “Mueller” of the type and style noted on the Standard Details or approved equal. Included as a part of the service connection shall be the furnishing and installation of the meter box complete with a cast iron traffic lid, set flush with the proposed finished grade of the lot in the designated location near the property line, all as shown on the Standard Details.

Service lines between the main and the property line shall be placed at a trench depth sufficient to maintain a 3-foot cover over the top of the service line for its full length, taking into consideration the final finished grade of the proposed street and the final finished grade of any storm ditches.

W-9 LARGE METER AND TESTS

If extensions require water meters 3 inches or larger, then such entire meter installations, including but not limited to, valves, piping, vaults, drain lines and meters shall be coordinated with City staff.

Where sub-meters are installed, all sub-meters shall be of the same manufacturer as the master meter to ensure compatibility, accuracy, and consistency in metering systems.

W-11 HYDROSTATIC PRESSURE TEST

The water mains shall be hydrostatically tested before being placed in service. Water for testing must be obtained by the Developer by arrangement with the City. A positive displacement type pump shall be furnished by the Developer for the testing. Feed for the pump shall be from a disinfected clean container, wherein the actual amount of “makeup” water can be measured.

Upon completion of sections of the pipe installation, the water main shall be pressure tested in segments of 1,000 lineal feet or less. The test pressure shall be either 200 pounds per square inch, or twice the system pressure, using the greater value, and shall maintain the test for a period of not less than 2 hours.

Pressure testing against existing valves shall not be permitted unless authorized by the City.

The Developer shall provide temporary plugs, caps and blocking as required to pressure test and disinfect the new water main prior to making connections to the existing system.

Concrete thrust blocking for fittings shall be in place and the concrete "set" sufficiently to withstand the test pressure before starting the test.

All pressure tests shall be made with the hydrant auxiliary gate valves open and pressure against the hydrant valve. After this basic pipe line test has been completed, each valve shall be tested including the hydrant auxiliary valve by closing each in turn and relieving the pressure beyond. This test of the valves will be acceptable if there is no immediate loss of pressure on the gauge when the pressure comes against the valve being checked. The Developer shall verify and assure that the pressure differential across the valve does not exceed the rated working pressure of the valve.

Prior to calling for the City to witness the pressure test, the Developer shall first perform a satisfactory pressure test. The allowable leakage rate per thousand feet of each size pipeline is as follows:

Allowable Leakage	
<u>Pipe Size</u>	<u>Gallon per hour per 1,000 Ft. @ 200 psi</u>
6"	0.64
8"	0.85
10"	1.06
12"	1.28
16"	1.70

Any leakage caused by defective workmanship or materials shall be repaired, and the line shall again be tested to full compliance.

All visible leaks in pipelines or fittings shall be repaired even if the test results fall within the allowable leakage.

W-12 DISINFECTION OF WATER MAINS

Water mains and appurtenances shall be disinfected in accordance with AWWA C651 before being placed in service. Water for disinfection must be obtained by the Developer by arrangement with the City.

The method of placing calcium hypochlorite granules in the water main as it is being installed is acceptable if the pipe and appurtenances are kept clean and dry during construction.

The calcium hypochlorite granules contain approximately 65 percent available chlorine by weight. The minimum amount of calcium hypochlorite granules placed at the beginning and in each 500 feet of pipe is as follows:

<u>Pipe Size Calcium Hypochlorite Granules</u>	
6"	1.0 oz.
8"	2.0 oz.
12"	4.0 oz.
16" and larger	8.0 oz.

When the line is completed and ready to disinfect, water shall be allowed to flow in slowly, until it appears at the far end of the line so as not to displace the disinfecting agent. The system shall then be allowed to stand for at least 24 hours. The line shall then be flushed through the fire hydrants until a test shows the CL2 residual no longer exceeds distribution system residual.

In all instances, the Developer shall utilize a state approved double check valve type backflow prevention device to protect the potable water supply while filling, flushing and disinfecting the particular water main.

In the process of chlorinating newly laid water pipe, all valves, fire hydrants and other appurtenances shall be operated while the pipeline is filled with the chlorinating agent.

The Developer is herein advised that prior to making any restoration or permanent connections to the existing water mains the Developer shall first demonstrate to the City that the new water main has adequately passed a pressure test, been adequately flushed, and finally passed the required bacteriological test.

In all disinfection processes, the Developer shall take particular care in flushing and wasting the chlorinated water from the mains to assure that the flushed and chlorinated water does no physical or environmental damage to property, streams, storm sewers or any waterways. Flushing water must be disposed of in accordance with Washington State Department of Ecology Standards. Flushing

water shall require dechlorination or disposal to sewer system to prevent damage to the affected environment, particularly aquatic and fish life of receiving streams.

Before placing the lines in service, a satisfactory bacteriological report or approval shall be received from a State approved laboratory on samples collected from representative points in the new system. The City shall collect all samples for the bacteriological tests. However, the Developer shall notify the City requesting collection of samples 2 working days in advance, and schedule on days wherein samples can be conveniently processed by a State Department of health approved laboratory. If any of the pipeline materials are replaced thereafter, then that section shall again be disinfected, pressure tested and tested for bacteriological count.

If disinfection of mains by the above methods prove unsatisfactory and the lab report indicates any type of bacteria count, then the Developer shall re-chlorinate using other methods in accordance with AWWA C691, approved by the City.

W-13 CONNECTIONS TO EXISTING SYSTEMS

All cut-in connections to the existing system shall be made after a successful pressure test of the new main has been witnessed by the City and after a purity test has been satisfactorily evidenced.

Size on size connections shall utilize stainless steel full circle tapping tee or DI cut-in tee.

Where it is necessary to shut-off the existing (or new) mains to make a connection, the Developer shall notify the City 72 hours or 3 working days in advance of such shut-off, and the City will notify customers of the shut-off, provide temporary services to critical customers and shut-off the mains. Connections shall be performed between the hours of 9:00 a.m. and 4:30 p.m. only. No cut-in connections or connections of new piping to the existing piping shall be scheduled for Fridays or Mondays. Once the water has been shut-off, the Developer shall diligently pursue the connection to completion, so that the time required for the shut-off may be held to a minimum. The City will notify customers in the area of the scheduled shut-off.

The required connections shall not be started until all of the materials, equipment and labor necessary to properly complete the work are assembled on the site. All connections shall be completed the same day they are started. The Developer shall time its operations so that water will not be shutoff overnight or over weekends or holidays.

The location, type and size of existing facilities have been determined from available records and are approximate. It is anticipated that connections to these existing facilities may be made, in general, as shown on the Plans, except where adjustments are required for vertical and horizontal alignment.

It shall be the responsibility of the Developer to determine the exact horizontal and vertical location of connections, ascertain the type and size of existing facilities and determine potential conflicts prior to starting work on any connection. Alternatives shall be provided as required to complete the connection detail.

Connections to existing facilities shall be made with the use of fittings, valves, flexible couplings, solid sleeves, shackling and other miscellaneous fittings, including thrust blocks as shown on the Plans and with additional pipe or fittings as approved by the City.

Where connections are made to existing facilities and it is impractical to use the methods described herein to disinfect the section between the existing water main and the point of installation of the new water main (valve or temporarily plugged line) the Developer shall clean and swab the pipe, fittings and valves with a minimum 5 percent chlorinated solution immediately before making said connection and thereby disinfect the necessary connection.

All pipe and fittings used for the connection shall be clean and disinfected. The Developer shall take extra precautions to ensure the tightness of the connections, nuts and bolts. The existing water main shall be placed back into service by the City and the connection observed for leakage by the City prior to backfilling the pipe.

END PART 2

S-1 SEWER MAINS, LATERALS AND FORCE MAINS

Sewer pipe shall be polyvinyl chloride (PVC) or polyethylene or epoxy lined ductile iron (DI) all sizes unless specifically noted otherwise.

Sewer mains to be installed shall be of material noted below:

Gravity Sewer and Laterals:

PVC Pipe: up to 18' Cover

DI Pipe: 18' and Over
Slopes of 18 percent or greater with approval of the City

Force Main: DI Pipe

All types of pipe shall be handled in a manner that will prevent damage to the pipe, pipe lining or coating. Pipe and fittings shall be loaded and unloaded using hoists and slings in a manner to avoid shock or damage, and under no circumstances shall they be dropped, skidded, or rolled against other pipe. Damaged pipe will be rejected, and the Developer shall immediately place all damaged pipe apart from the undamaged and shall remove the damaged pipe from the site within 24 hours.

Dirt or other foreign material shall be prevented from entering the pipe or pipe joint during handling or laying operations, and any pipe or fitting that has been installed with dirt or foreign material in it shall be removed, cleaned, and relayed. A clean whiskbroom shall be used for this purpose and for brushing to remove foreign matter prior to joining of pipe ends. At times when pipe laying is not in progress, the open ends of the pipe shall be closed by a watertight plug or by other means approved by the City to ensure cleanliness inside the pipe.

Pipe shall be stacked in such a manner as to prevent damage to the pipe, to prevent dirt and debris from entering the pipe, and to prevent any movement of the pipe. The bottom tiers of the stack shall be kept off the ground on timbers, rails or other similar supports. Pipe on succeeding tiers shall be alternated by bell and plain end. Timbers 4 inch by 4 inch in size shall be placed between tiers and chocks shall be placed at each end to prevent movement. For safety each size of pipe shall be stacked separately.

Immediately upon beginning pipe installation, the Contractor shall place and secure a watertight plug in the sewer manhole. The plug shall remain in place throughout the project until such time as the project is accepted by the City. Failure to place the plug or removal of a plug prior to approval shall be ground for City issued penalties.

A. PVC Pipe and Fittings

The PVC pipe shall be a minimum Class S.D.R. 35 and be manufactured in accordance with ASTM D3034. The pipe and fittings shall be furnished with bells and spigots, which are integral with the pipe wall. Pipe joints shall use flexible elastomeric gaskets conforming to ASTM D3212. Nominal laying lengths shall be 13 feet.

Tees for side sewer laterals shall be 6-inch-diameter fabricated tees. No field cut-in tees will be allowed without approval of the City.

If approved by the City, the connection shall be made by machine-made tap and Romac Style Sewer "CB" Saddle or Inserta Tee, available from Fowler Manufacturing Company or equal.

The gravity sewer pipe, unless otherwise approved by the City shall be laid upgrade from point of connection on the existing sewer or from a designated starting point. The sewer pipe shall be installed with the bell end forward or upgrade. When pipe laying is not in progress, the forward end of the pipe shall be kept tightly closed with an approved temporary plug. Wherever movable shoring (steel box) is used in the ditch, pipe shall be restrained by use of a winch mounted in the downstream manhole and a line of sufficient strength threaded through the pipe and set tight before each move. Any indication that joints are not being held shall be sufficient reason for the City to require restraints, whether or not movable shoring is being used.

All gravity sewer pipe shall be laid in straight lines and at uniform rate of grade between manholes. Variance from established line and grade shall not be greater than 1/2 inch, provided that such variation does not result in a level or reverse sloping invert; provided, also, that variation in the invert elevation between adjoining ends of pipe, due to non-concentricity of joining surface and pipe interior surfaces, does not exceed 1/64 inch per inch of pipe diameter, or a total of 1/2 inch maximum. Any corrections required in line and grade shall be reviewed with the City and the repairs shall be made at the expense of the Developer.

Pipe handling after the gasket has been affixed shall be carefully controlled to avoid disturbing the gasket and knocking it out of position, or fouling the gasket with dirt or other foreign material. Any gaskets so disturbed shall be removed, cleaned, re-lubricated if required, and replaced before the rejoining is attempted.

Care shall be taken to properly align the pipe before joints are forced entirely home. During insertion of the tongue or spigot, the pipe shall be partially supported by hand, sling or crane to minimize unequal lateral pressure on the

gasket and thereby maintain concentricity until the gasket is properly positioned. Since most flexible gasketed joints tend to creep apart when the end pipe is deflected and straightened, such movement shall be held to a minimum once the joint is home.

Sufficient pressure shall be applied in making the joint to assure that it is home, as described in the installation instructions provided by the pipe manufacturer. Sufficient restraint shall be applied to the line to assure that joints once home are held so, until fill material under and alongside the pipe has been sufficiently compacted. At the end of the workday, the last pipe laid shall be blocked in an effective way to prevent creep during "down time."

All gravity sewer pipe shall be bedded with gravel as shown on the details. The pipe shall be bedded from a depth of 4 inches below the pipe to 12 inches above the pipe. The bedding material shall extend across the full width of the trench and shall be compacted under the haunches of the pipe.

Special concrete bedding when required to provide additional support for the pipe shall consist of a pipe cradle constructed of Portland cement concrete containing not less than four sacks of cement per cubic yard. Sand, gravel and water proportions are subject to approval by the City. Maximum aggregate size shall be one and 1-1/2 inches. Maximum slump shall be 4 inches. The bottom of the trench shall be fully compacted before the placement of pipe cradle. The Developer shall protect pipe against flotation and disturbing the horizontal alignment of the pipe during the pouring of the concrete.

Clay or bentonite dams shall be installed across the trench, keyed into native undisturbed soil and to the full depth of the granular material in all areas of steep slopes, stream crossings and within wetlands to prevent migration of water along the pipeline. The City shall determine where trench dams are required.

B. Ductile Iron Pipe and Fittings

DI pipe may be used, under special circumstances only, with approval of the City. The ductile iron pipe shall conform to AWWA C151 Standards, except the minimum nominal thickness shall be as follows:

- 6" - 0.25" (Class 52)
- 8" - 0.27" (Class 52)
- 10" - 0.29" (Class 52)
- 12" - 0.31" (Class 52)

Grade of iron shall be 60-42-10. The pipe shall be polyethylene or epoxy lined to a nominal thickness of 40 mils. Minimum lining thickness shall be 30 mils. The exterior shall be coated with an asphaltic coating. Products meeting the

standard are US pipe "Polylined," "Protecto 401" and American Pipe "Polyband" or approved equal.

Each length shall be plainly marked with the manufacturer's identification, year cast, thickness, class of pipe and weight. The pipe shall be furnished with mechanical joint or push-on joint, conforming to AWWA C111 Standards, except where otherwise noted calling for flanged joints.

Restrained joint pipe, where shown on the Plans, shall be push-on joint pipe with "Field Lok" gaskets or TR FLEX as furnished by US Pipe, or approved equal.

The pipe manufacturer shall certify in writing that the inspection and all tests of the specified standards for both pipe and gaskets being supplied for this project have been made and that the results thereof comply with the requirements of the Standard.

Joints shall be "made-up" in accordance with the manufacturer's recommendations. Standard joint material, including rubber ring gaskets shall be furnished with the pipe. Materials shall be suitable for the specified pipe sizes and pressures. The pipe joint utilized shall be the patented "Tyton" joint.

All fittings shall be short-bodied, ductile iron complying with applicable AWWA C110 or C153 Standards. All fittings shall be polyethylene or epoxy lined and either mechanical joint or flanged, as indicated on the Plans.

Fittings in sections shown on the Plans requiring restrained joints shall be mechanical joint fittings with a mechanical joint restraint device. The mechanical joint restraint device shall have a working pressure of at least 250 psi with a minimum safety factor of 2:1 and shall be EBAA Iron, Inc., MEGALUG, Romac Industries, Inc., Grip Ring Pipe Restrainer or approved equal. Stargrip Series 3000 mechanical joint restraint devices are not accepted or approved as equal.

Fittings shall be adequately "blocked" with poured-in-place concrete, within wooden forms shaped to establish a firm minimum bearing area, against an undisturbed earth wall as shown on the Standard Details. Timber blocking will not be permitted. The concrete thrust blocks must be in place at least 24 hours before beginning the pressure test, to allow the concrete to "set." The strength of the concrete shall be 2,000 psi minimum.

All fittings requiring a concrete block shall first be covered with 20-pound tarpaper, before concrete is poured. The concrete shall not cover joints, bolt heads or nuts.

All bolts shall be coated with Armite Anti-Seize Compound No. 609, or equal, prior to installation.

All connections to ductile or cast iron pipe shall be with ductile iron mechanical joint sleeves except as shown on the Plans for mechanical joint tees, valves, etc.

C. High Density Polyethylene Pipe (HDPE)

HDPE pipe may be used, under special circumstances only, with approval of the City. Approval shall be subject to a case-by-case review of the proposed application and of the proposed pipe and installation specifications. Design calculations shall be submitted to support the proposed SDR-rating, with respect to surge pressure and buckling, for City review and approval.

HDPE pipe shall conform to AWWA C-906. The HDPE pipe shall be butt-fused welded pipe (Driscopipe Prisma 4200 or equivalent) and shall be high-density, PE 3408 pipe. The material shall have a long-term hydrostatic strength of 1,600 psi per ASTM D2837.

The pipe shall be made from polyethylene resin compound. Type III, Category 5, Class C, Grade P34 per ASTM D-1248. The minimum cell classification shall be PE334434C for PE 3408 materials per ASTM D-3350. The manufacturer shall provide the proper certification to ensure the materials comply with the specification's requirements.

The material shall contain a sufficient UV stabilization for 24 months of outdoor storage.

The manufacturer shall furnish an affidavit that all materials delivered comply with the requirements of the specifications together with copies of the test results (nominal values).

The manufacturer shall furnish a certification that Compressed Ring Test (ASTM F-1248) has been utilized to test for environmental stress crack resistance and results equal or exceed $F > 5,000$ hours.

The pipe shall be homogenous throughout and uniform in density, color and other properties.

Pipe markings shall include name or trademark of pipe fabricator, pipe outside diameter, standard dimension ratio (SDR), polyethylene cell classification per ASTM D-3350, production code from manufacturing location, name of manufacturer, and date of production.

Pipe and polyethylene fittings shall be produced by the same manufacturer from identical material meeting the requirements of this specification. Polyethylene fittings may be molded, or fabricated by heat fusion joining polyethylene

components prepared from pipe, molded fittings, or polyethylene sheet or block, except fittings 8-inches nominal diameter and smaller shall be molded meeting the requirements of ASTM D-3261. Fittings fabricated from pipe shall be manufactured from pipe stock with a wall thickness not less than 25 percent greater than that of the pipe to which the fitting is to be jointed. The wall thickness of an outlet may be the same as the wall thickness of the pipe to which the outlet is to be jointed. Flange fittings to ductile iron pipe shall comply with ANSI 150 and shall be designed and manufactured at not less than the design pressure of the system.

With the City’s prior approval, electrofusion couplings may be used to facilitate pipe installation in the vicinity of existing utilities. Electrofusion couplings shall meet the standard of AWWA C906.

Thermal stability of resin:	ASTM D-3350 (220 degrees C) ⁽⁴⁾
Ring-tensile strength test:	ASTM D-2290 92,900 psi) ⁽¹⁾
Elongation-at-break test:	ASTM D-638 (750%) ⁽⁴⁾
Carbon black content:	ASTM D-4218 (2% min.; 3% max.) ⁽²⁾
Melt index:	ASTM D-1238 (0.1 gm/10 min.) ⁽²⁾
Density:	ASTM D-1505 (0.955 gm/cm ³) ⁽²⁾
Toe-in:	ASTM D-2122 (<1.5% smaller than average O.D., 12" from end) ⁽³⁾
Environmental stress crack resistance:	ASTM D-1693 (F>192 hours min.) ⁽⁴⁾

Frequency of Tests:

- (1) At least one per production run.
- (2) At least one per day (24 hours).
- (3) At least one per day (or one per each 8-hour shift).
- (4) At least one per resin lot.

Flanged joining of pipe shall be performed with a convoluted ductile iron backup flange conforming to the vital dimensions of ANSI 16.5. The flange shall be epoxy coated ductile iron conforming to ASTM 536, Grade 65/45/12.

Gaskets provided at all flanged joints shall be Buna “N,” grade 60, or equal suitable for wastewater. Bolts and nuts for flanged joints shall be low-carbon steel conforming to ASTM A-307, 60,000 psi tensile strength, grade B. The bolts shall be evenly tightened using a crossing pattern and each flanged joint shall be checked and retightened after 1 hour or more has passed.

Flexible couplings used for connections of high-density polyethylene to ductile iron pipe shall include an adaptor ring. Adaptor ring shall be pre-fabricated lap joint (follower ring) per ASTM 207 Class “D” with two sets of bolt circles. One bolt circle to match the lap joint bolt pattern and the other bolt circle to match the

bolt pattern of a Standard Class 125 flange. Gasket shall be made of rudder 1/8-inch full face type. Bolts shall be provided as required for the connection. Flanges shall have a fusion bonded epoxy coating.

The polyethylene (HDPE) pipe shall be handled, stored, and installed so as to avoid physical damage to the pipe including cuts or gouges to depths in excess of 10 percent of wall thickness. The damaged portions of the pipe shall be removed and the undamaged portions rejoined using the thermal butt fusion joining method unless the pipe is acceptable to the City and manufacturer.

Sections of polyethylene pipeline shall be joined into continuous lengths by the butt fusion method above ground along the trench or by flanged connections in the trench as required to avoid existing utilities. The joining method shall be performed by personnel trained to assemble the pipe and in strict accordance with the pipe manufacturer's recommendation. The pipe shall be assembled as a continuous piping system to avoid the need for thrust blocks for thrust restraint at bends or fittings for thrust restraint.

In some cases along the pipeline, the manufacturers recommend bending radius may be exceeded and may require a fabricated fitting. All fabricated fittings shall be fully pressure rated and configured to conform to the total deflection angle noted on the Plans. As an alternative, fully pressure rated mitered fittings are acceptable.

Thermal butt fusion joining of the polyethylene pipe shall be performed with field-proven equipment that has a centerline guidance system to hold the pipe and fittings in close alignment while the opposing butt ends are faced, cleaned, melted and fused together and then cooled, all in strict accordance with the pipe manufacturer's recommendations. Butt fusion joining shall be 100 percent efficient offering a joint weld strength equal to or greater than the tensile strength of the pipe.

Butt fusion joining of polyethylene pipe of unlike SDRs shall not be permitted unless assembled by butt fusion procedures as recommended by the manufacturer and approved by the City. Alternatively, joining of pipe with unlike SDRs shall be performed with flanged connections.

Care shall be taken to install the HDPE pipe in accordance with the pipe manufacturer's recommendations. Standard installation practice shall include techniques recommended by the manufacturer to compensate for high thermal expansion and contraction characteristics of HDPE pipe, including adequate backfill compaction, snaking the pipe in the trench, and making tie-in connections at anticipated operating temperatures.

Where an HDPE main connects to or passes through a buried structure, such as a manhole, valve vault or wet well, the connection to the structure shall be made using a ductile iron wall spool or sleeve cast or grouted into the structure wall. The force main shall transition from HDPE to ductile iron pipe outside the manhole using a flange adapter with a ductile iron backing ring, or other approved method. The transition shall occur within the greater of 1 foot or 1-1/2 pipe diameters of the structure wall. The connection shall be anchored against pull-out at the structure in accordance with the pipe manufacturer's recommendations.

D. Side Sewer Laterals

A side sewer lateral is considered to be that portion of a sewer line that will be constructed between a main sewer line and a property line or easement limit line.

All applicable specifications given herein for sewer construction shall be held to apply to side sewer laterals. The side sewer lateral shall be of the same material as the mainline, except as noted in the Standing Side Sewer Detail.

Side sewers shall be for a single service connection only and be a minimum 6-inch-diameter pipe. Side sewers shall be connected to the tee, provided in the sewer main where such is available, utilizing approved fittings or adapters. The side sewer shall rise at a maximum of 45 degrees and a minimum of 2 percent, extending from the sewer main.

The maximum bend permissible at any one fitting shall not exceed 45 degrees. Any bend, or combination of bends equaling 45 degrees shall consist of or be followed by a wye clean out.

Where there are no basements, the minimum side sewer depth shall be 6 feet below existing curb line and 5 feet below ground at the property line, except where existing improvements, proposed improvements or topography may dictate additional depth. The elevations of the side sewer connections shall be of sufficient depth to serve all existing and potential future basements.

Sewer Grinder Pumps are not allowed except by special approval from the City. Where standard conforming gravity service cannot be achieved and denial of service is the only remaining option, private ownership of grinder pumps may be considered by the City. The Developer's Engineer shall provide the City with information utilized in determining gravity service unavailability showing that all means of achieving gravity service, regardless of cost, have been reviewed and eliminated. If it is proven that gravity service is unavailable, only then will the City accept the Developers Engineer's proposal identifying pump design and the areas to be served for City review and approval.

E. Grease Interceptors

When specified by the City, grease interceptors shall be provided for all Commercial, Industrial or School food establishments. When specified by the City interceptor shall be installed as close as possible to source of grease/fat. A Sample Chamber shall be installed immediately downstream of the grease interceptor. Grease interceptor shall be provided in accordance with Washington State Department of Ecology Standards.

F. Oil and Water Separators

Oil and water separators shall be provided in accordance with applicable Washington State Department of Ecology Standards. The installation of such systems is mandatory where industrial, commercial, or vehicular activities pose a risk of oil or hydrocarbon discharge into the municipal storm or sanitary sewer systems. The design, capacity, and flow rate of all oil and water separators must be submitted to and approved by the City prior to installation. All separators must be appropriately sized based on anticipated influent characteristics and site-specific conditions, and shall comply with all local, state, and federal environmental regulations.

S-2 MANHOLES

Manholes shall be of the offset type and shall be precast concrete sections with either a cast in place base, or a precast base made from minimum 3,000 psi structural concrete. Joints between precast wall sections shall be confined O-ring or as otherwise specified. All manholes over 20 feet in depth shall be a minimum of 54 inches in diameter.

For connections to existing manholes, a concrete coring machine, suitable for this type of work, shall be utilized in making the connection. The existing manhole shall be rechanneled as required. The new pipe connection shall be plugged (water tight) until the new pipe system has been installed and approved. The Developer shall be responsible for any existing defects in the existing manhole unless these defects are witnessed by the City prior to any work being performed to make the connection. The Developer shall be required to remove any and all deleterious material in the existing manhole and downstream reaches as a result of their connection.

The Developer shall excavate completely around the manhole to prevent unbalanced loading. The manhole shall be kept in operation at all times and the necessary precautions shall be taken to prevent debris or other material from entering the sewer.

A. Manhole Sections

Manhole sections shall be placed and aligned so as to provide vertical sides and vertical alignment of the ladder steps. The completed manhole shall be rigid, true to dimension, and be watertight. Rough, uneven surfaces will not be permitted.

B. Manhole Steps and Ladders

Manhole steps shall be polypropylene, MA Industries, 1/2-inch Grade 60 steel, PS2-PF or equal.

Ladders shall be polypropylene MA Industries or equal, and shall be compatible with the steps.

C. Grade Adjustment

Each manhole shall be provided with not less than 14 inches or more than 18 inches of grade adjustment between the top of the cone and the top of the manhole frame.

Masonry units or precast concrete adjustment rings shall be installed to adjust to final grade. The outside and inside of manhole adjusting bricks or rings and the joints of precast concrete sections shall be plastered and troweled smooth with 1/2 inch (minimum) of mortar in order to attain a watertight surface.

In unpaved areas, a 4-foot-diameter by 8-inches-thick concrete collar shall be poured around the manhole with a manhole marker post unless prior authorization has been granted by the City.

D. Channels

Channels shall be made to conform accurately to the sewer grade and shall be brought together smoothly with well-rounded junctions, satisfactory to the City. The channels shall be field poured after the inlet and outlet pipes have been laid and firmly grouted into place at the proper elevation. Allowances shall be made for a 0.1-foot drop in elevation across the manhole in the direction of flow. Channel sides shall be carried up vertically from the invert to three-quarters of the diameter of the various pipes. The concrete shelf shall be warped evenly and sloped 3/8 inch per foot to drain. Rough, uneven surfaces will not be permitted. Channels shall be constructed to allow the installation and use of a mechanical plug or flow meter of the appropriate size.

E. Pipe Connections

All pipe connections to the manhole shall be with grouting a heavy-duty sand collar, or equal into the manhole wall.

G. Lift Holes and Steel Loops

All lift holes shall be completely filled with expanding mortar, smoothed both inside and outside, to insure water tightness. All steel loops shall be removed, flush with the manhole wall. The stubs shall be covered with mortar and smoothed. Rough, uneven surfaces will not be permitted.

H. Frames and Covers

Frames and covers shall be ductile iron as shown on the standard detail. Castings shall be free of porosity, shrink cavities, cold shuts or cracks, or any surface defects, which would impair serviceability. Repair of defects by welding, or by the use of "smooth-on" or similar material, will not be permitted. Frames and covers shall be machine finished or ground on seating surfaces so as to assure non-rocking fit in any position and interchangeability of covers.

Frames and covers shall be adjusted to conform to the final finished surface grade of the street or easement to the satisfaction of the City.

J. Manhole Fall Protection

All manholes that are 20 feet or over in depth, measured from finished grade to invert of the pipe, shall be a minimum of 54 inches in diameter (or a size specified by the City) to facilitate the use of fall protection equipment.

S-3 TESTING GRAVITY SEWERS

The Developer shall furnish all facilities and personnel for conducting tests under the observation of the City. Methods other than low-pressure air test shall be subject to the approval of the City.

A. Preparation for Testing for Leakage

Before any leakage test is performed, the Developer shall clean and flush all gravity sewer lines with an approved rodding method or with a cleaning ball and clean water prior to testing. The inflatable diagonally ribbed rubber ball shall be of a size that will inflate to fit snugly into the pipe to be tested. After completion of backfill and cleaning, the completed gravity sewer, including side sewer stubs, shall be televised inspected. This will be permitted prior to paving. If the television inspection reveals excess debris, the Developer shall clean and televise again at its own expense. The sewer shall then be tested by the low-

pressure air test method but only after all utilities are installed and the project paved. Except, however, that in certain conditions an exfiltration test may be required by the City.

The first section of pipe, not less than 300 feet in length, installed by each crew shall be tested in order to qualify the crew and/or the material. A successful installation of this first section shall be a prerequisite for further pipe installation by the crew. At the Developer's option, crew and/or material qualification testing may be performed at any time during the construction process after at least 2 feet of backfill has been placed over the pipe.

All debris flushed out of the line shall be removed at the first manhole where its presence is noted. In the event cemented or wedged debris or a damaged pipe shall stop the cleaning operation, the Developer shall remove the obstruction, and/or repair any damaged pipe. All visible leaks showing flowing water in pipelines or manholes shall be stopped even if the test results fall within the allowable leakage. The cleaning shall be carried out in such a manner as to not infiltrate water into existing facilities. Precautions shall be taken to prevent any damage caused by cleaning and testing. Any damage resulting shall be repaired by the Developer at its own expense. The manner and time of testing shall be subject to approval of the City.

B. Low Pressure Air Test

The sewer pipe shall be tested for leaks through the use of air in the following manner:

Immediately following the pipe cleaning and television inspection, the pipe installation shall be tested with low-pressure air. Air shall be slowly supplied to the plugged pipe installation until the internal air pressure reaches 4.0 pound per square inch greater than the average back pressure of any ground water that may submerge the pipe. At least 2 minutes shall be allowed for temperature stabilization before proceeding further.

The rate of air loss shall then be determined by measuring the time interval required for the internal pressure to decrease from 3.5 to 2.5 pounds per square inch while maintaining the stipulated pressure greater than the pipe section's average adjacent groundwater back pressure.

The pipeline shall be considered acceptable if the total rate of air loss from any section tested in its entirety between manholes, cleanouts or pipe ends does not exceed the following table:

TABLE OF TEST TIME IN MINUTES AND SECONDS
Length of 6" Pipe (ft.)

Length of 8" Pipe (ft.)		0	50	100	150	200	250	300	350	400
	0	0	0:40	1:20	1:58	2:38	3:18	3:58	4:38	5:16
	50	1:10	1:50	2:30	3:10	3:48	4:28	5:08	5:48	5:56
	100	2:20	3:00	3:40	4:20	5:00	5:38	6:14	6:12	6:08
	150	3:32	4:10	4:50	5:30	6:10	6:30	6:26	6:22	6:18
	200	4:42	5:22	6:00	6:40	6:44	6:38	6:34	6:30	6:26
	250	5:52	6:32	6:48	6:58	6:50	6:44	6:40	6:36	6:32
	300	7:02	7:20	7:10	7:02	6:06	6:50	6:44	6:40	6:36
	350	7:34	7:22	7:14	7:06	7:00	6:54	6:50	6:44	6:42
	400	7:34	7:24	7:16	7:08	7:02	6:58	6:52	6:48	6:44

Test times will be provided by the City for combinations other than 8-inch mains and 6-inch laterals.

If the pipe installation fails to meet these requirements, the Developer shall determine at its own expense the source or sources of leakage, and shall repair (if the extent and type of repairs proposed by the Developer appear reasonable to the City) or replace all defective materials or workmanship. The completed pipe installation shall meet the requirements of this low-pressure air test or the alternative water exfiltration test before being considered for acceptance.

Plugs used to close the sewer pipe for the air test shall be securely braced with non-buoyant material to prevent the unintentional release of a plug, which can become a high velocity projectile. Gauges, air piping manifolds and valves shall be located at the top of the ground. No one shall be permitted to enter a manhole where a plugged pipe is under pressure. Air testing apparatus shall be equipped with a pressure release device such as a rupture disk or a pressure relief valve designed to relieve pressure on the pipe under test at 6 psi.

S-4 TESTING FORCE MAINS

The force mains shall be hydrostatically tested before being placed in service. Water for testing must be obtained by the Developer by arrangement with the City. A positive displacement type pump shall be furnished by the Developer for the testing. Feed for the pump shall be from a container, wherein the actual amount of "makeup" water can be measured.

The test pressure shall be either 200 pounds per square inch, or twice the system pressure, using the greater value and shall maintain the test for a period of not less than 1 hour. The test pressure shall be applied at the low end of the section tested.

The Developer shall provide temporary plugs, caps and blocking as required to pressure test the new force main.

Concrete thrust blocking for fittings shall be in place and the concrete "set" sufficiently to withstand the test pressure before starting the test.

Prior to calling for the City to witness the pressure test, the Developer shall first perform a satisfactory pressure test. The allowable leakage rate per thousand feet of each size pipeline is as follows:

<u>Pipe Size</u>	<u>Allowable Leakage Gal. per Hour per 1,000 Ft. @ 200 psi</u>
6"	0.64
8"	0.85
10"	1.06
12"	1.28

Any leakage caused by defective workmanship or materials shall be repaired, and the line shall again be tested to full compliance.

S-5 TELEVISED INSPECTION

After manhole adjustment, installation of pavement, channeling and the gravity sewer lines have been cleaned and flushed, the Developer shall provide a complete televised inspection.

The Developer shall perform a complete televised inspection of the sewer pipe and appurtenances and shall provide to the City, a 1/2-inch VHS colored audio-visual tape recording, DVD or CD of the inspections together with a written log of the television inspection. The camera shall be a pan and tilt type equipped with adequate light and focusing to allow inspection of sewer main, side sewers and full circumference inspection of main line joints and fittings. The City shall determine if the quality of the tape is acceptable.

Immediately prior to the televised inspection, the Developer shall run water through each sewer line for 5 to 10 minutes to provide water for detection of any adverse grade sections visible by the presence of ponded water. The camera shall be stopped periodically at the ponded areas and the depth of water shall be measured with a ball of known diameter on the pull line. Ponding shall not be greater than 1/16-inch per inch of pipe diameter and not exceed 1/2 inch in

depth. During the inspection, all tees and other fittings shall be logged as to exact location within 1 percent maximum error in measurement, wherein accuracy is checked with various fittings and the terminating manhole.

The City shall be notified 48 hours prior to any television inspection and this work shall be performed on a schedule to allow the City to witness the inspection.

If the television inspection shows indications of deflections in the pipe, the City may require that the Developer pull a proper sized mandrel for the main through the pipe to confirm that the pipe deflection does not exceed the manufacturer's recommendations.

Any defects in material or installation identified by the television inspection shall be repaired as required by the City at the Developer's expense.

END PART 3

ST-1 EXCAVATION AND SUBGRADE PREPARATION

Existing material shall be excavated and hauled from the project site as necessary to accommodate the proposed finished grade and roadway section. If the subgrade is disturbed during excavation, the subgrade shall be compacted prior to placing new roadway material.

Unsuitable subgrade materials, including but not limited to: unstable or soft soils such as peat, muck, and clay; roots, buried logs, buried stumps, garbage, or other debris shall be excavated and hauled from the project site. Unsuitable foundation excavation shall be replaced with Gravel Borrow. If needed to stabilize soft material, the excavation shall be lined with construction geotextile for separation before placing gravel borrow.

Construction Geotextile for Separation shall conform to the material requirements of Section 9-33 of the WSDOT Standard Specifications.

Gravel Base shall conform to the material requirements of Section 9-03.10 of the WSDOT Standard Specifications.

ST-2 ROADWAY CONSTRUCTION

New roadway construction (including full width construction, partial width construction, and patching) shall consist of an 8-inch compacted depth layer of Crushed Surfacing Base Course below a bituminous wearing course. The wearing course shall consist of either: (1) a 2-inch compacted depth layer of Commercial HMA; or (2) a Bituminous Surface Treatment with two applications of emulsified asphalt aggregate.

Roadway edges shall consist of a 6-foot-wide, 4-inch compacted depth Crushed Surfacing Base Course shoulder or cement concrete curb, gutter, and sidewalk.

Pavement joints shall consist of neat line sawcut edge and shall receive a tack coat prior to paving. Apply asphalt paving sealant to joints.

Asphalt thickened edge and asphalt berms shall be constructed of Commercial HMA along a straight, neat line, and shall be graded to drain. If constructed after wearing course is in place, joints shall be sealed with paving asphalt.

Paved surfaces intended for use as pedestrian walkways shall be constructed in accordance with the requirements for slope, grade, dimensions, and surface smoothness, and other criteria set forth by the Americans with Disabilities Act (ADA) and detailed in the WSDOT Field "Guide for Accessible Public Rights of Way" and the United States Access Board "Proposed Accessibility Guidelines for Pedestrian Facilities in the Public Right-of-Way."

Crushed Surfacing Base Course shall conform to the construction and material requirements of Section 4-04 of the WSDOT Standard Specifications.

Commercial HMA shall conform to the construction and material requirements of Section 5-04 of the WSDOT Standard Specifications.

Bituminous Surface Treatment shall conform to the construction and material requirements of Section 5-02 of the WSDOT Standard Specifications.

ST-3 CONCRETE CURBS AND PEDESTRIAN FACILITIES

All pedestrian facilities shall be constructed in accordance with the requirements for slope, grade, dimensions, and surface smoothness, and other criteria set forth by the Americans with Disabilities Act (ADA) and detailed in the WSDOT "Field Guide for Accessible Public Rights of Way" and the United States Access Board "Proposed Accessibility Guidelines for Pedestrian Facilities in the Public Right-of-Way"

Cement Concrete Curb and Gutter, Cement Concrete Pedestrian Curbs, and other curbs including extruded curb shall conform to the construction and material requirements of Section 8-04 of the WSDOT Standard Specifications.

Cement Concrete Driveway Entrances shall conform to the construction and material requirements of Section 8-06 of the WSDOT Standard Specifications.

Cement Concrete Sidewalks and Cement Concrete Curb Ramps shall conform to the construction and material requirements of Section 8-14 of the WSDOT Standard Specifications.

END PART 4

STANDARD DETAILS

STORM DETAILS

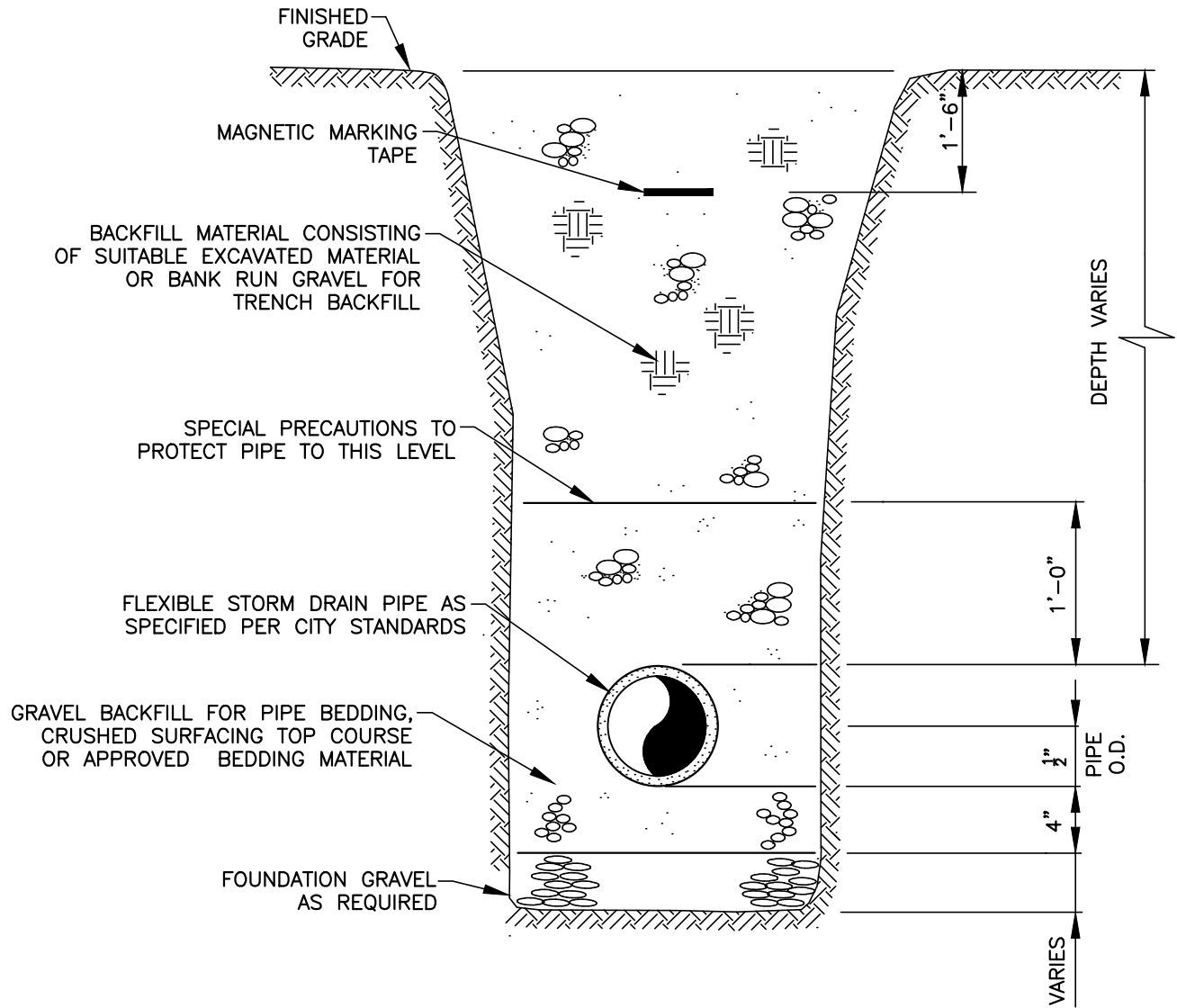

REV:9/14

BRIDGEPORT
Washington State

FIGURE SD-1
STORM DRAIN TRENCH SECTION

Gray & Osborne, Inc.

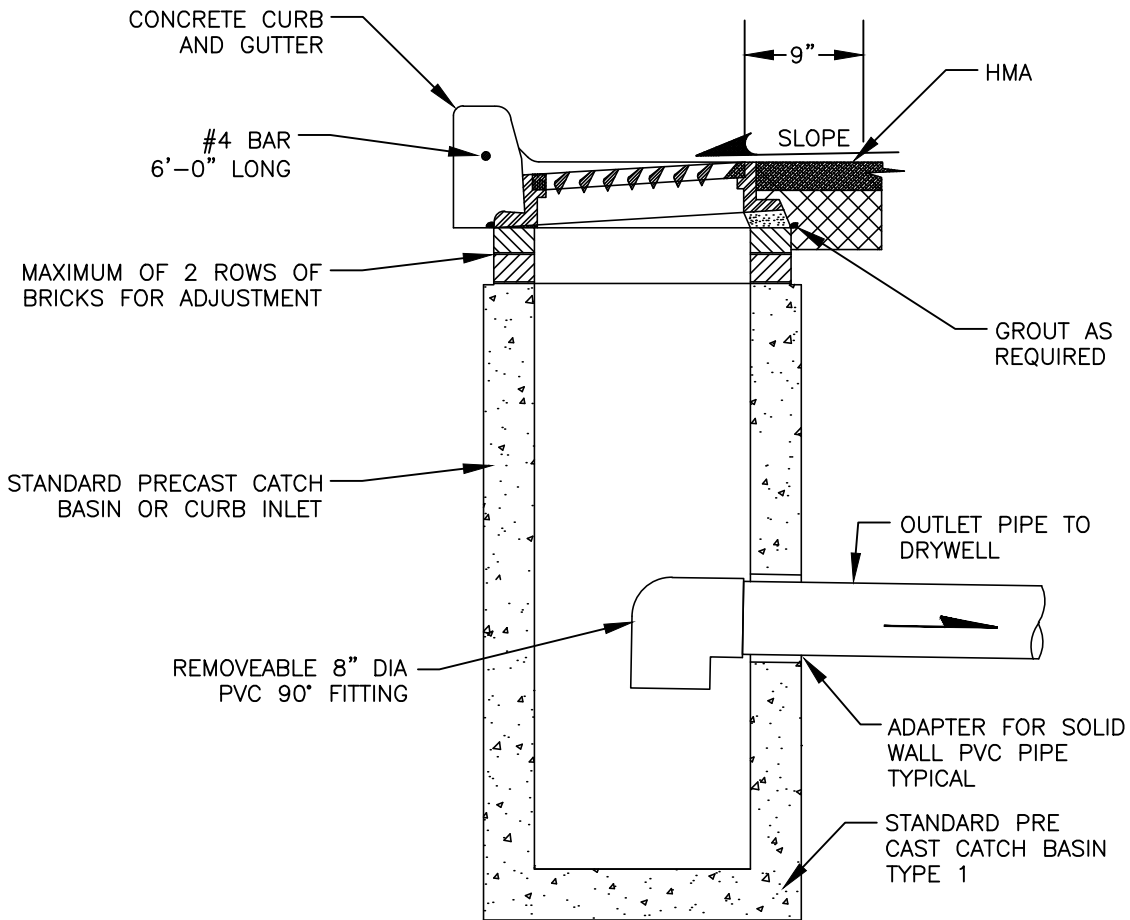
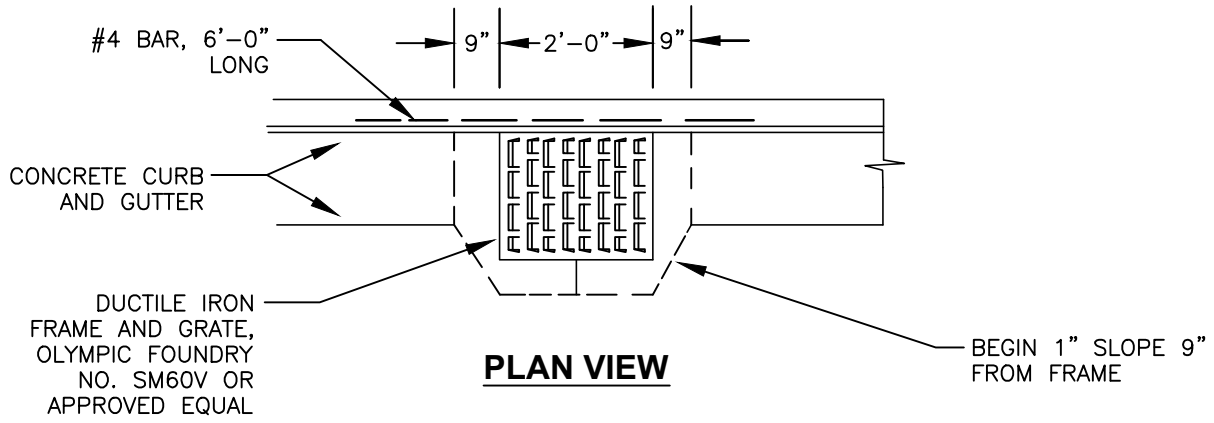

PROFILE VIEW



FIGURE SD-2
CATCH BASIN TYPE 1



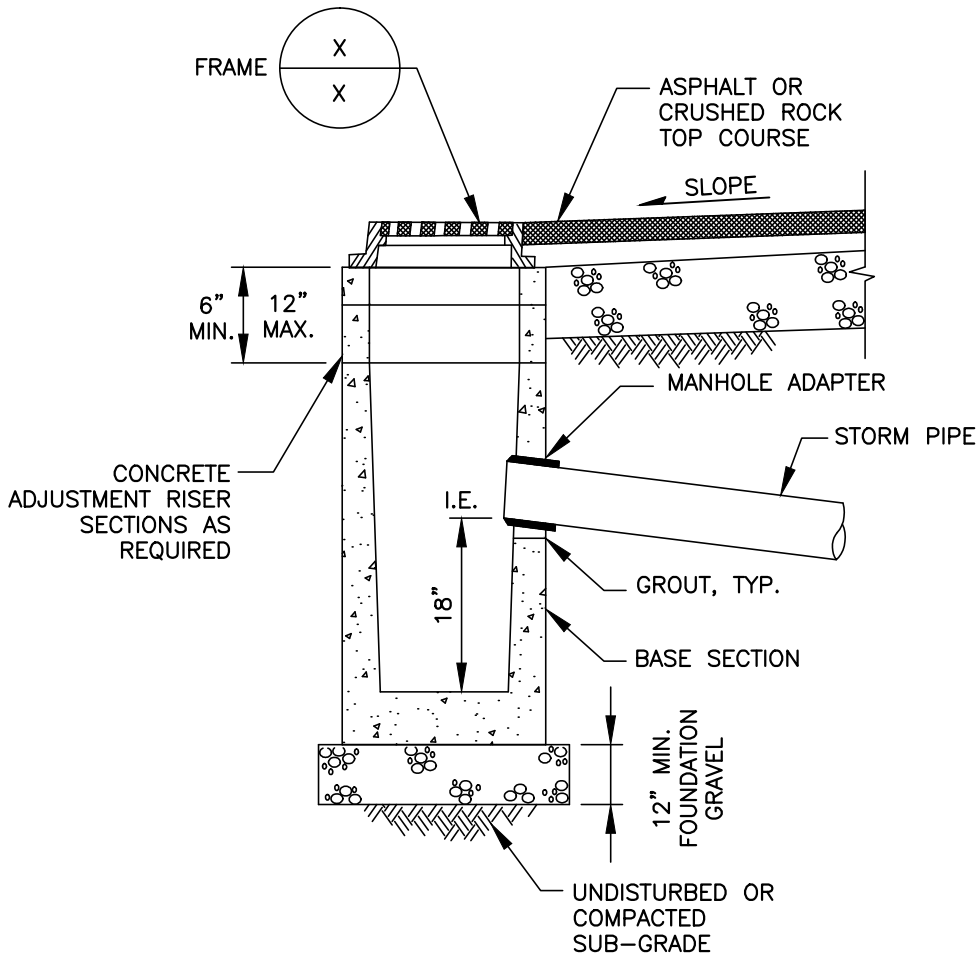

NOTE:
 FOR PIPE INSTALLATION,
 REFER TO STORM SEWER
 TRENCH SECTION DETAIL.



FIGURE SD-3
 CATCH BASIN TYPE 1A



REV:9/14

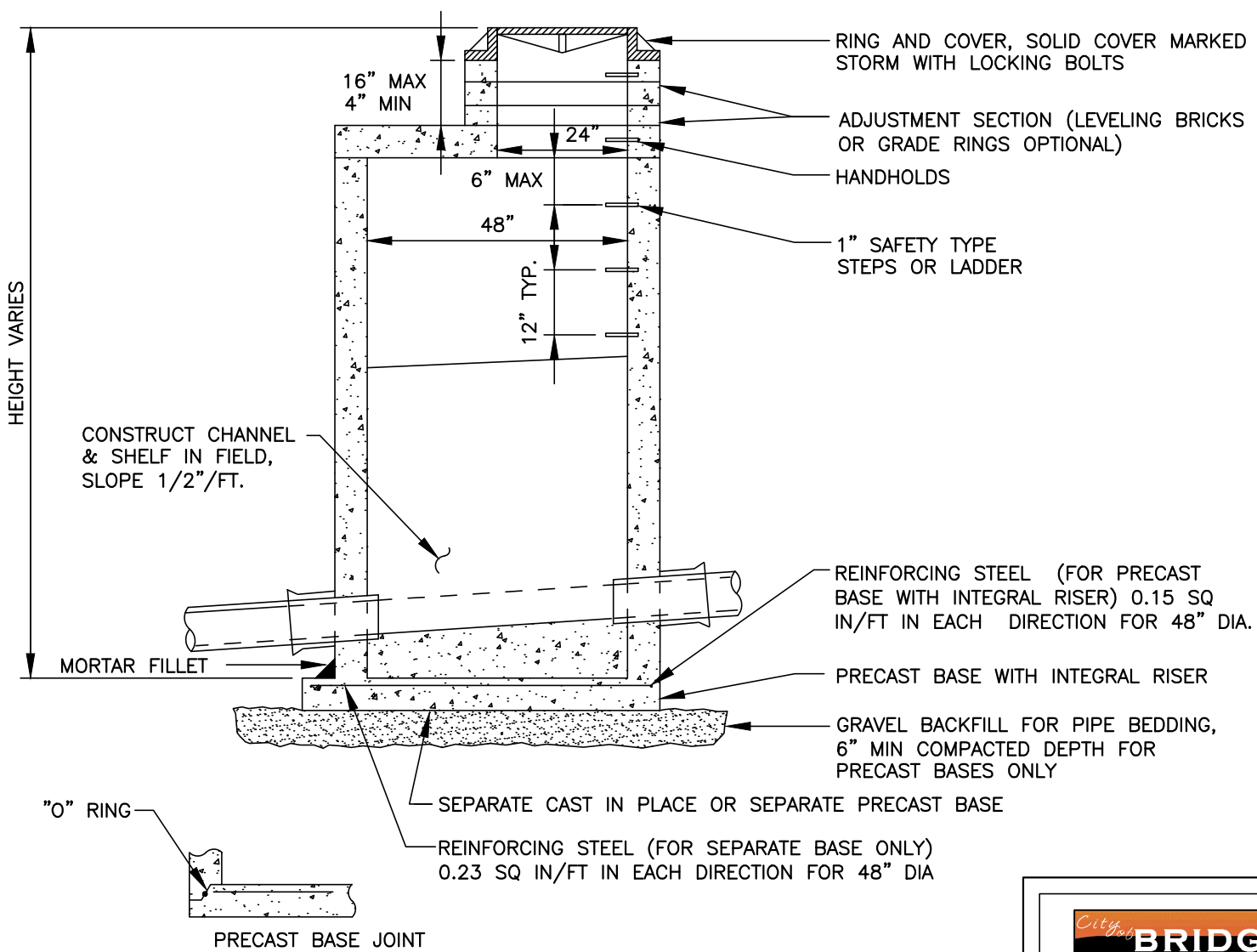

BRIDGEPORT
Washington State

DETAIL SD-4
CATCH BASIN - TYPE 2

Gray & Osborne, Inc.

REV:9/14

L:\BRIDGEPORT\14052 CONSTRUCTION STANDARDS\DEVELOPER STANDARDS\SD-08 TYPE2A

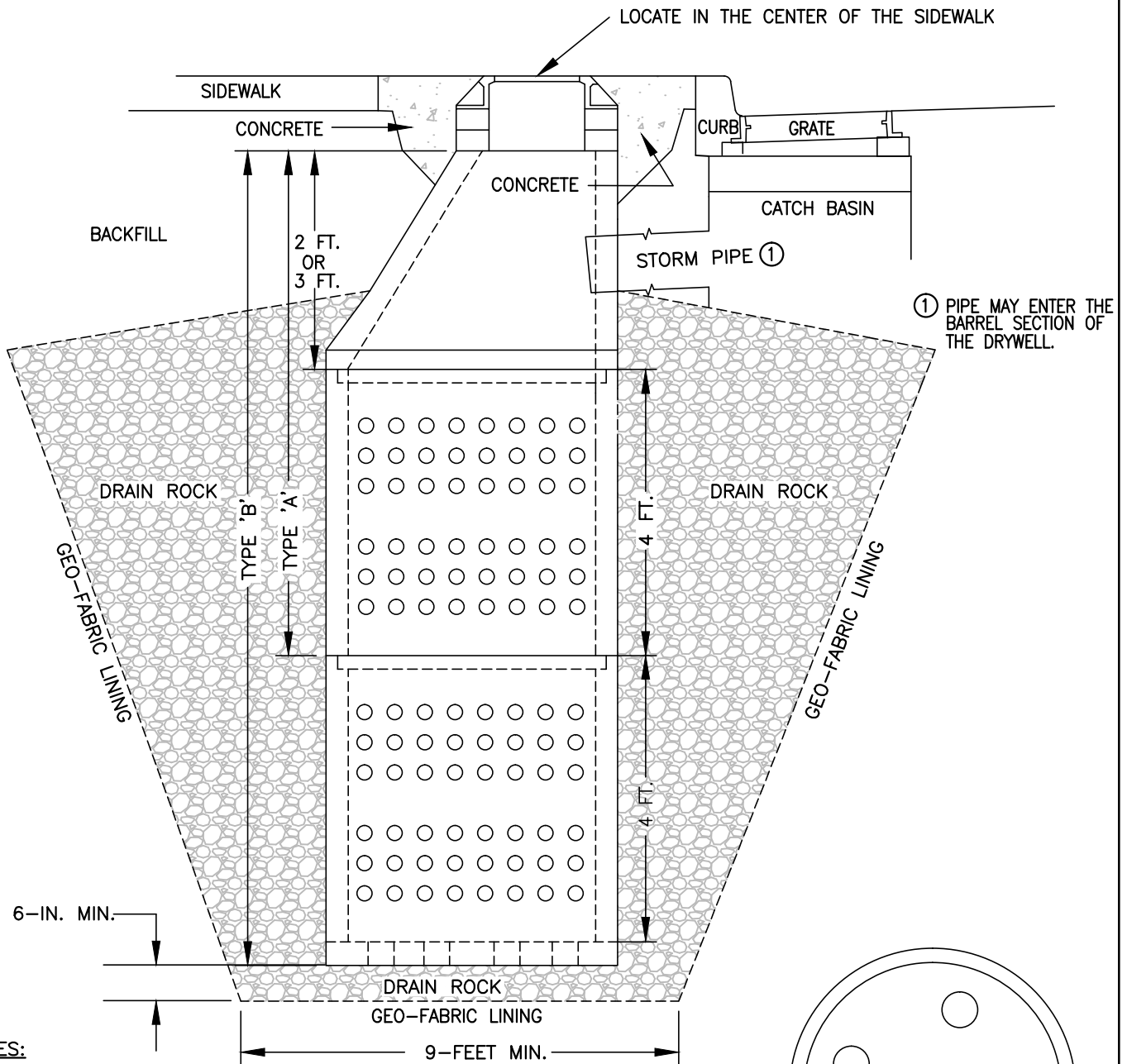

NOTES:

1. MINIMUM OF ONE 4-INCH ADJUSTMENT RING WITH A MAXIMUM OF 16 INCHES OF ADJUSTMENT.
2. PLACE CONCRETE AROUND OUTSIDE OF ADJUSTMENT RINGS AND RING TO PREVENT INFILTRATION/EXFILTRATION.
3. PRECAST CONE SECTION MAY BE CONCENTRIC OR ECCENTRIC.
4. GROUT SEAL PVC PIPE WHERE THE PIPE PENETRATES THE DRYWELL.
5. DRYWELLS NOT IN SIDEWALK SHALL BE PLACED IN A 6-FT. BY 6-FT. BY 6-IN. CONCRETE PAD AT FINISH GRADE.
6. STORM PIPE SHALL BE A MINIMUM OF 18 FEET IN LENGTH.
7. "STORM" SHALL BE CAST IN THE LID AND FRAME AND GRATE SHALL COMPLY WITH SEC. 9-05.15(1) OF THE COMMUNITY STREET AND UTILITY CONSTRUCTION STANDARDS.

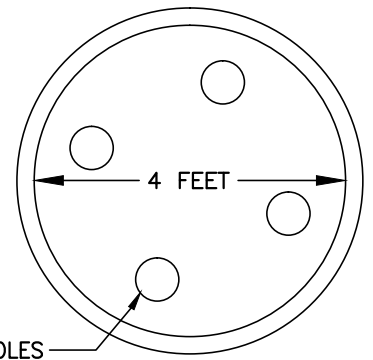

PRECAST BASE DETAIL

L:\BRIDGEPORT\14022 CONSTRUCTION STANDARDS\DEVELOPER STANDARDS\W-DRYWELL MANHOLE

REV:9/14



BRIDGEPORT
Washington State

DETAIL SD-5
CONCRETE DRYWELL MANHOLE



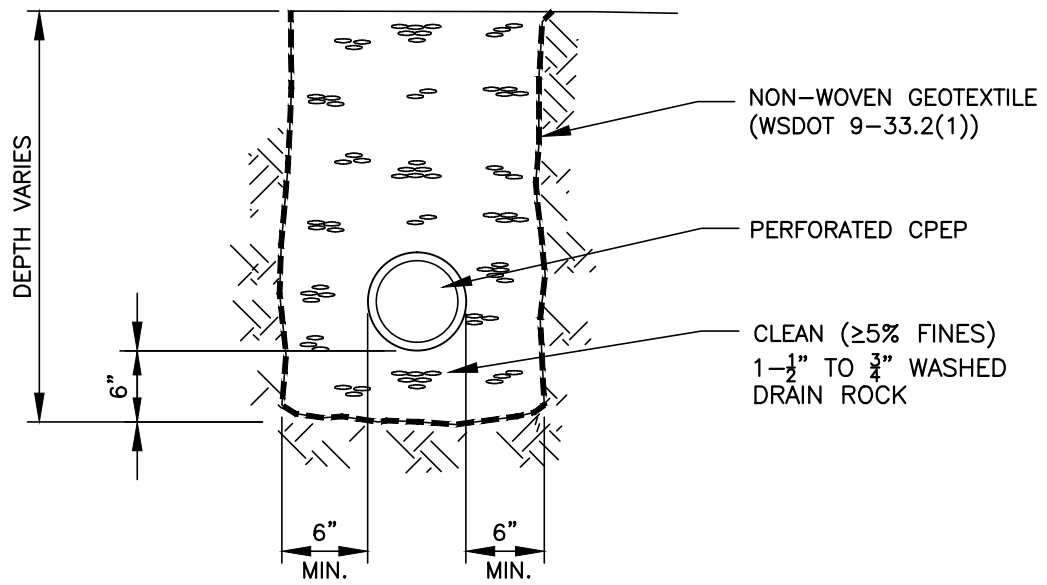

REV:9/14

BRIDGEPORT
Washington State

FIGURE SD-6
INFILTRATION TRENCH

Gray & Osborne, Inc.

L:\BRIDGEPORT\14082 CONSTRUCTION STANDARDS\DEVELOPER STANDARDS\SD-INFLTRATION CHAMBER

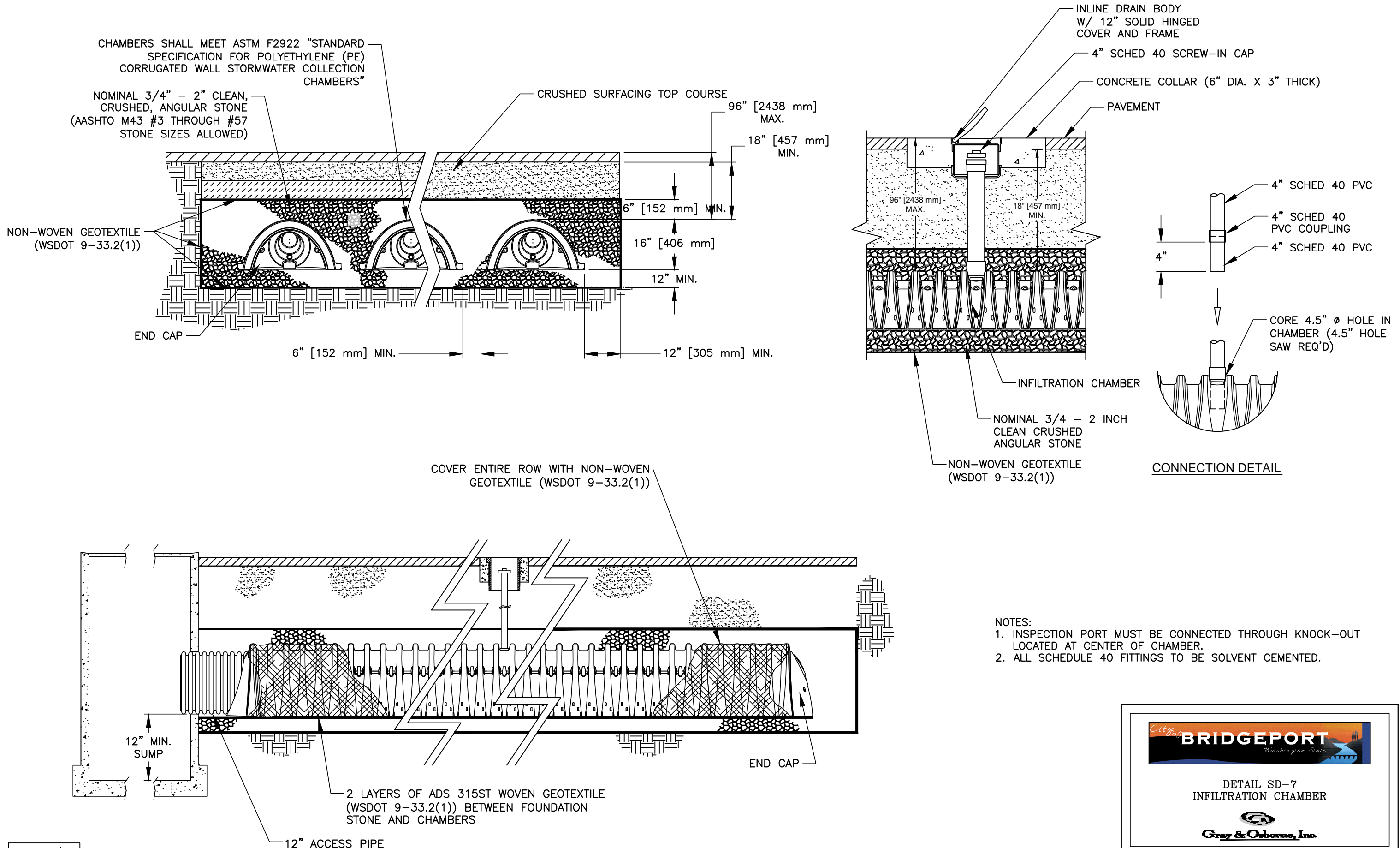

- NOTES:
- INSPECTION PORT MUST BE CONNECTED THROUGH KNOCK-OUT LOCATED AT CENTER OF CHAMBER.
 - ALL SCHEDULE 40 FITTINGS TO BE SOLVENT CEMENTED.

REV: 9/14



BRIDGEPORT
Washington State

DETAIL SD-7
INFILTRATION CHAMBER



WATER DETAILS

FINISHED GRADE

MAGNETIC MARKING TAPE

COMPACTED BACKFILL CONSISTING OF SUTABLE EXCAVATED MATERIAL OR BANK RUN GRAVEL FOR TRENCH BACKFILL AS AGREED TO BY THE ENGINEER, OBTAIN COMPACTION REQUIREMENTS.

SPECIAL PRECAUTIONS TO PROTECT PIPE TO THIS LEVEL

GRAVEL BACKFILL FOR PIPE BEDDING, CRUSHED SURFACING TOP COURSE OR APPROVED BEDDING MATERIAL

14 GAUGE TRACER WIRE, CONNECT BETWEEN VALVES

PVC WATER PIPE

FOUNDATION GRAVEL AS REQUIRED

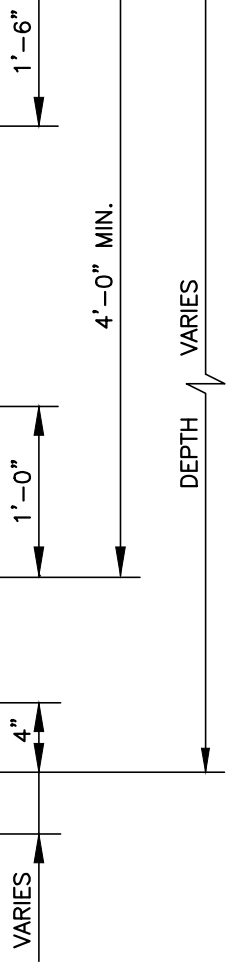

L:\BRIDGEPORT\4022 CONSTRUCTION STANDARDS\DEVELOPER STANDARDS\W-XX WATER MAIN TRENCH SECTION

REV:9/14

BRIDGEPORT
Washington State

DETAIL W-1
WATER MAIN TRENCH SECTION

Gray & Osborne, Inc.

MINIMUM BEARING AREA TABLE					
FITTING D	TEE	90°	45°	22 1/2°	11 1/4°
6"	4 SQ. FT.	6 SQ. FT.	3 SQ. FT.	2 SQ. FT.	2 SQ. FT.
8"	7 SQ. FT.	10 SQ. FT.	6 SQ. FT.	3 SQ. FT.	2 SQ. FT.
10"	10 SQ. FT.	15 SQ. FT.	9 SQ. FT.	5 SQ. FT.	3 SQ. FT.
12"	14 SQ. FT.	22 SQ. FT.	12 SQ. FT.	6 SQ. FT.	4 SQ. FT.
16"	25 SQ. FT.	38 SQ. FT.	21 SQ. FT.	11 SQ. FT.	7 SQ. FT.
18"	32 SQ. FT.	48 SQ. FT.	27 SQ. FT.	14 SQ. FT.	8 SQ. FT.

TYPICAL FOR SANDY SOIL WITH 2,000 P.S.F. BEARING STRENGTH & 100 P.S.I. WORKING PRESSURE. ADJUST BEARING AREA BY PRESSURE & SOIL BEARING CAPACITY. USE TEE FOR DEAD ENDS

NOTES:

1. BLOCKING SHALL BE TO SOLID BEARING SURFACE.
2. FITTING SHALL BE PROTECTED WITH TAR PAPER.
3. BEARING AREA SHALL BE PROPORTIONALLY INCREASED WITH PRESSURES IN EXCESS OF 100 P.S.I OR IN SOIL CONDITIONS WITH LESS THAN 2,000 P.S.F BEARING STRENGTH.
4. ALL BLOCKS ON TEES SHALL BE SEPARATED FOR DIRECTION OF THRUST.

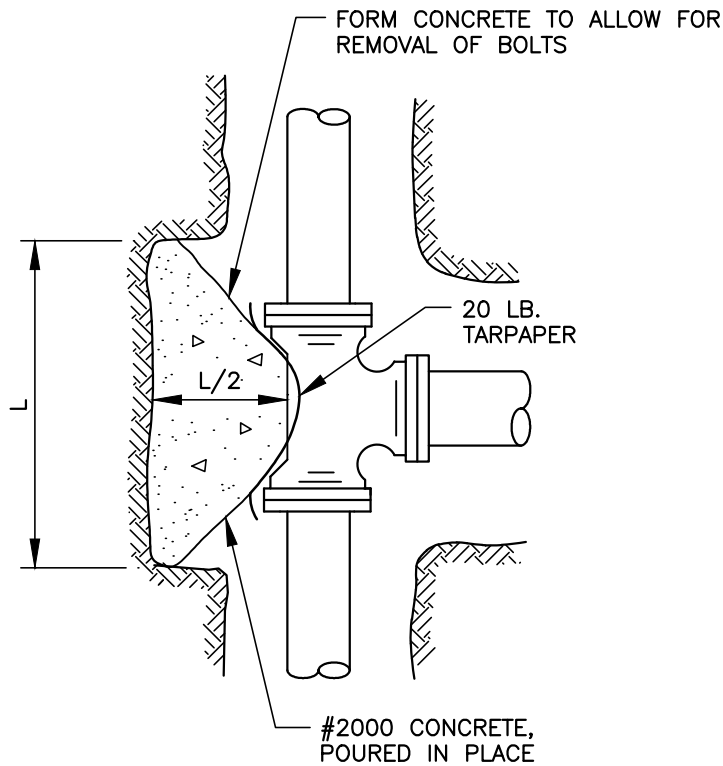

PLAN

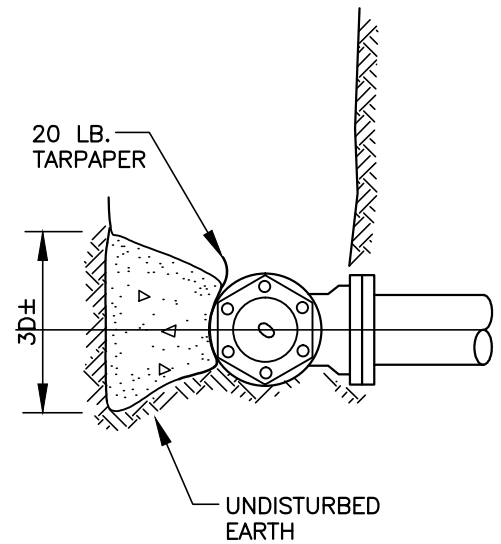

DETAIL W-2
THRUST BLOCKS



TYPE "A" BLOCKING
FOR 11 1/4° - 22 1/2° - 30° VERTICAL BENDS

PIPE SIZE NOMINAL DIAMETER— INCHES	TEST PRESSURE PSI	VB VERTICAL BEND DEGREES	No. OF CU. FT. OF CONC. BLOCKING	S SIDE OF CUBE LIN. FT.	D DIAM. OF SHACKLE RODS (2) INCHES	L DEPTH OF RODS IN CONCRETE LIN. FT.		
4"	300	11 1/4	8	2	5/8"	1.5		
		22 1/2	11	2.2		2.0		
		30	17	2.6				
6"	300	11 1/4	11	2.2	5/8"	2.0		
		22 1/2	25	2.9				
		30	41	3.5				
8"	300	11 1/4	16	2.5	5/8"	2.0		
		22 1/2	47	3.6				
		30	70	4.1			3/4"	2.5
12"	250	11 1/4	32	3.2	5/8"	2.0		
		22 1/2	88	4.5			7/8"	3.0
		30	132	5.1				
16"	225	11 1/4	70	4.1	7/8"	3.0		
		22 1/2	184	5.7			1 1/8"	4.0
		30	275	6.5				
20"	200	11 1/4	91	4.5	7/8"	3.0		
		22 1/2	225	6.1			1 1/4"	4.0
		30	330	6.9				
24"	200	11 1/4	128	5.0	1"	3.5		
		22 1/2	320	6.8			1 3/8"	4.5
		30	480	7.9				

TYPE "B" BLOCKING
FOR 45° VERTICAL BENDS

PIPE SIZE	TEST PRESSURE	VB	S	D	L	
4"	300	45	30	5/8"	2.0	
6"			68			4.1
8"			123			5.0
12"	250		232	3/4"	2.5	
16"	225		478	1 1/8"	4.0	
20"	200		560	1 1/4"		
24"			820	1 3/8"	4.5	

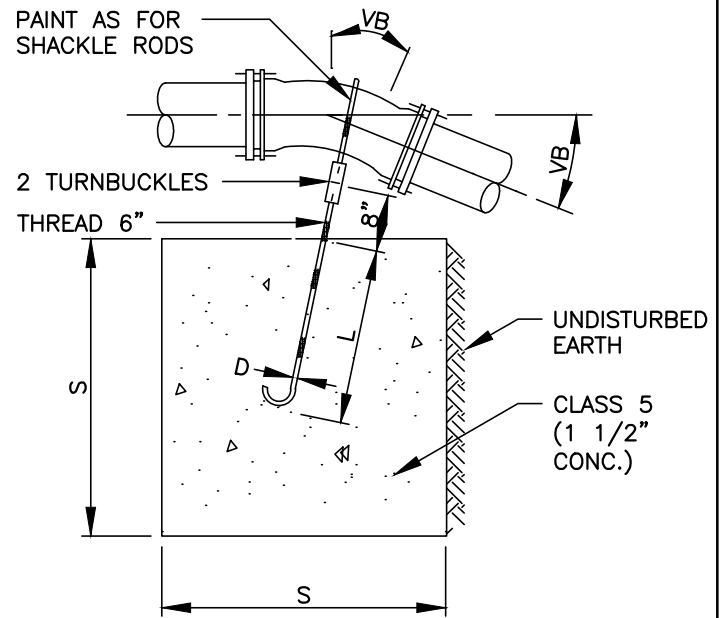

TYPE "A" BLOCKING

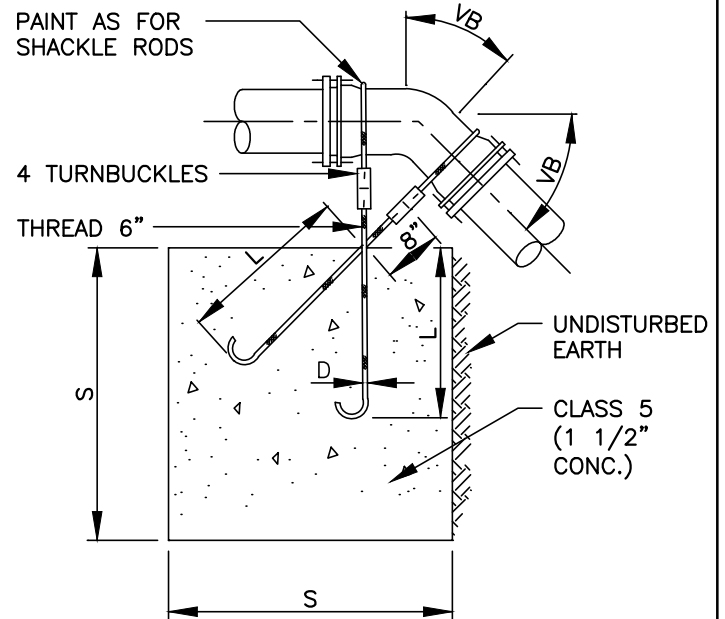

TYPE "B" BLOCKING



DETAIL W-3
VERTICAL ANCHOR BLOCK

Gray & Osborne, Inc.

REV:9/14

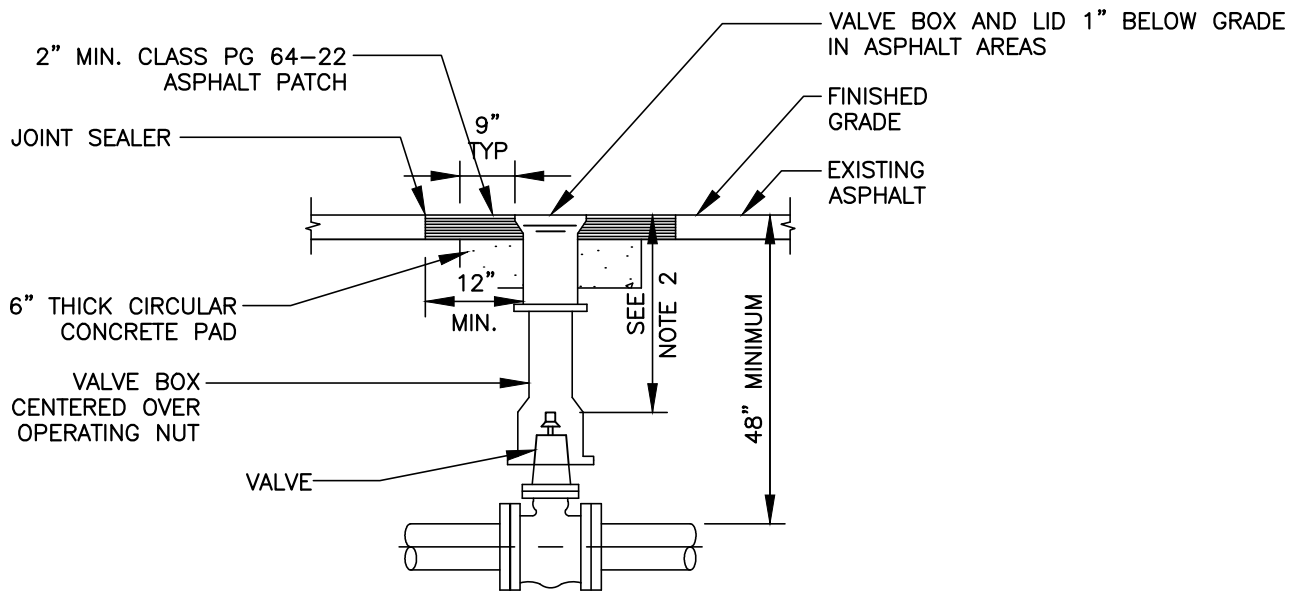

VALVE BOX IN ASPHALT AREA



VALVE BOX IN UNIMPROVED AREA (VALVE MARKER REQUIRED)

NOTES

1. EACH VALVE SHALL BE PROVIDED WITH AN ADJUSTABLE CAST IRON VALVE BOX OF 5 INCHES (5") INSIDE DIAMETER. VALVE BOXES SHALL HAVE A TOP SECTION WITH AN EIGHTEEN INCH (18") MIN. LENGTH. THE VALVE BOX SHALL BE RICH No. 940 OR SATHER MANUFACTURE. VALVE BOX EARS SHALL BE PLACED IN LINE WITH PIPE IT SERVES.
2. 18" MINIMUM, 24" MAXIMUM FOR OPERATOR NUT IF EXTENSION IS REQUIRED.

L:\BRIDGEPORT\4022 CONSTRUCTION STANDARDS\DEVELOPER STANDARDS\W-XX TYPICAL VALVE INSTALLATION

REV:9/14



BRIDGEPORT
Washington State

DETAIL W-4
TYPICAL VALVE INSTALLATION



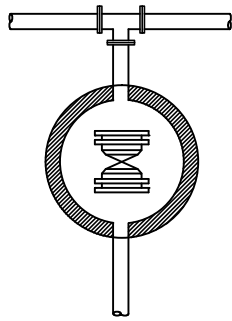

ALIGN "EARS" ON VALVE BOX TOP WITH DIRECTION OF PIPE BRANCH THE VALVE OPENS AND CLOSES.

PLAN VIEW

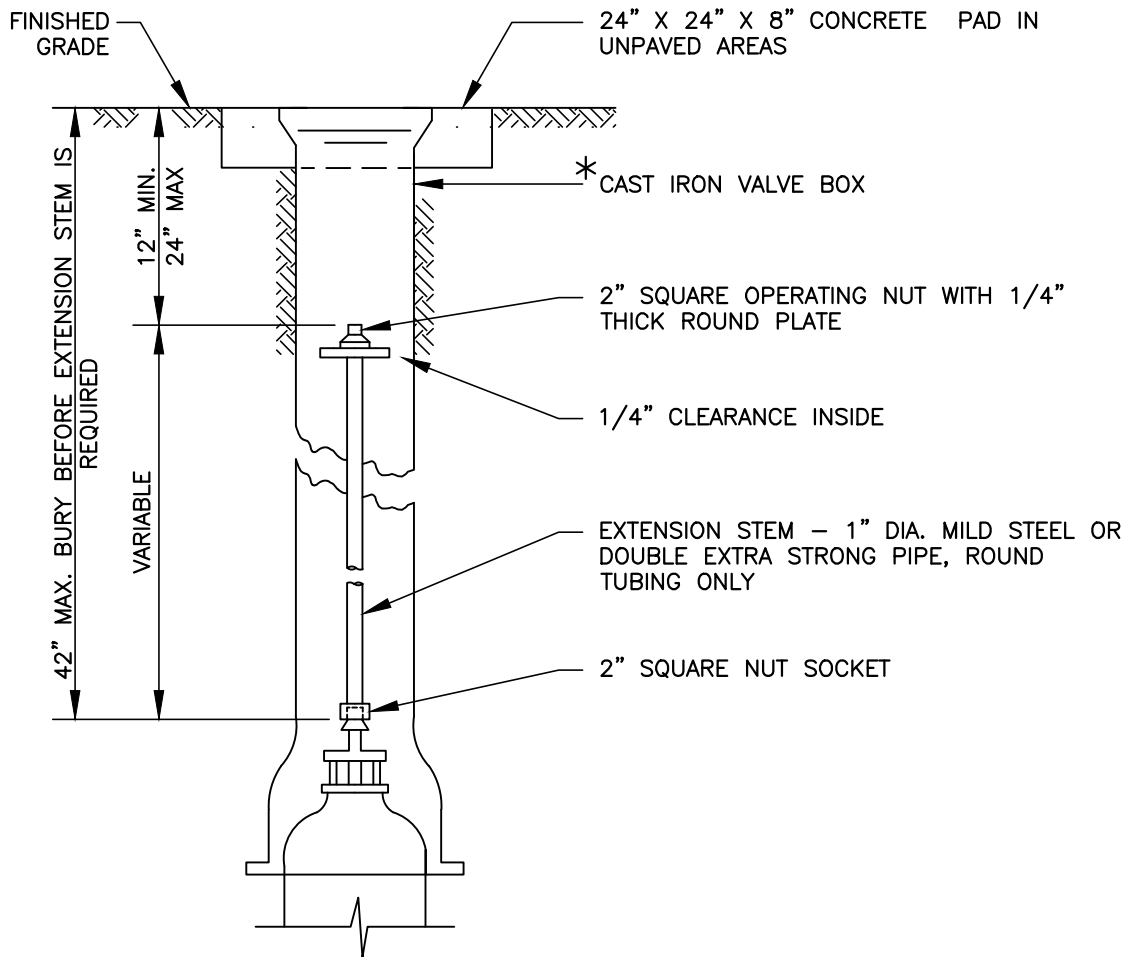

PROFILE VIEW

* CAST IRON VALVE BOX EXTENSION SHALL UTILIZE 5" CAST IRON "SOIL PIPE". BELL END TO BE PLACED OVER TOP OF VALVE BOX BOTTOM.

L:\BRIDGEPORT\4022 CONSTRUCTION STANDARDS\DEVELOPER STANDARDS\W-XX VALVE STEM EXTENSION

REV:9/14

DETAIL W-5
VALVE STEM EXTENSION

Gray & Osborne, Inc.

"CARSONITE" FIBERGLASS UTILITY
MARKER CUM375 WITH FLEXIBLE
ANCHOR BARB. COLOR: A.P.W.A. BLUE

3" x 3" HIGH INTENSITY WHITE
REFLECTOR (250 CANDLE POWER)

FINISHED GRADE

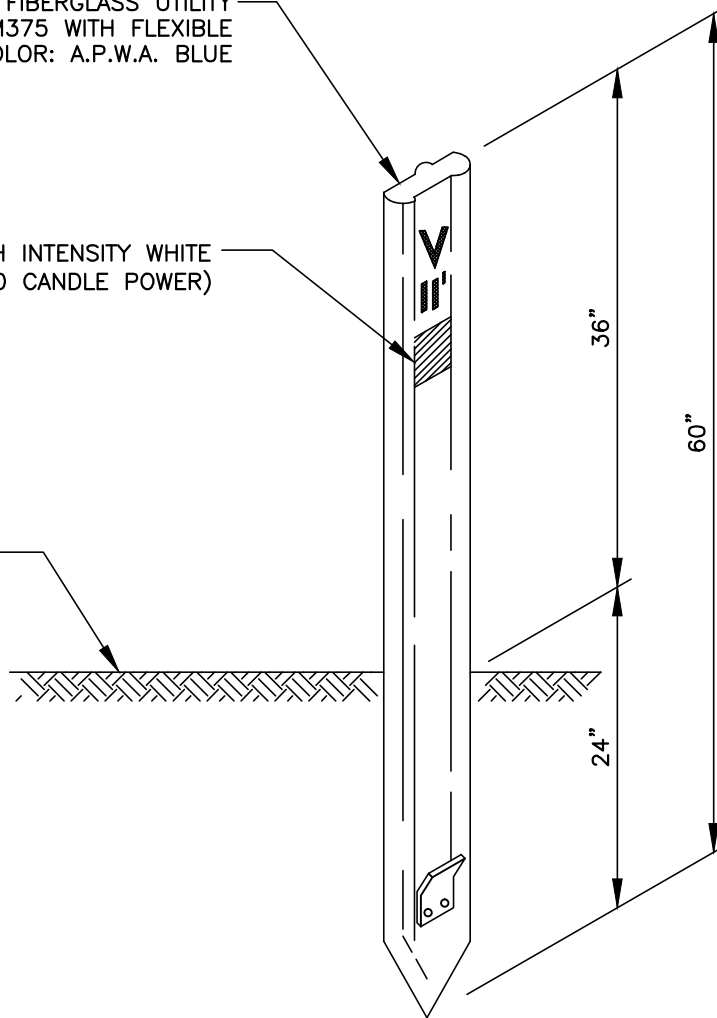

NOTES

1. THE LETTER "V" AND THE DISTANCE IN FEET TO THE VALVE SHALL BE ON THE POST WITH 2" HIGH DECALS DESIGNED FOR USE ON FIBERGLASS BOATS.
2. EACH POST SHALL INCLUDE THE FOLLOWING DECAL: "CAUTION WATER VALVE, BEFORE DIGGING, CALL 1-800-424-5555, UTILITY UNDERGROUND LOCATION CENTER."

L:\BRIDGEPORT\4022 CONSTRUCTION STANDARDS\DEVELOPER STANDARDS\W-XX VALVE MARKER

REV:9/14

City of **BRIDGEPORT**
Washington State

DETAIL W-6
VALVE MARKER

Gray & Osborne, Inc.

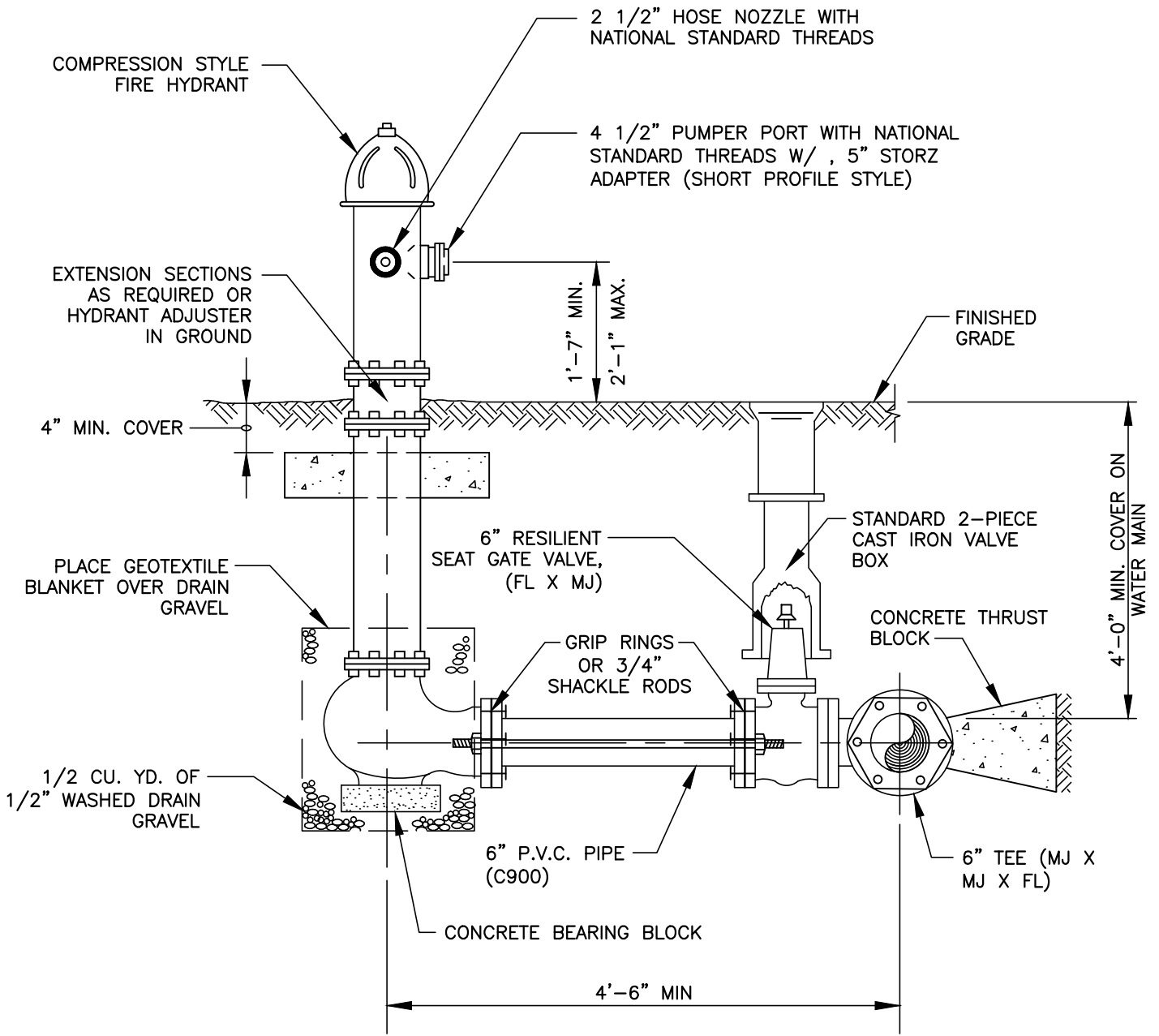

NOTES

1. PROVIDE MIN. 3'-0" CLEARANCE AND LEVEL AREA AROUND HYDRANT.
2. PAINT FIRE HYDRANT WITH TWO COATS OF YELLOW RUST-RESISTANT PAINT TO MATCH CITY'S EXISTING HYDRANTS.
3. ACCEPTABLE HYDRANTS: MUELLER CENTURION.



BRIDGEPORT
Washington State

DETAIL W-7
FIRE HYDRANT ASSEMBLY

Gray & Osborne, Inc.

REV:9/14

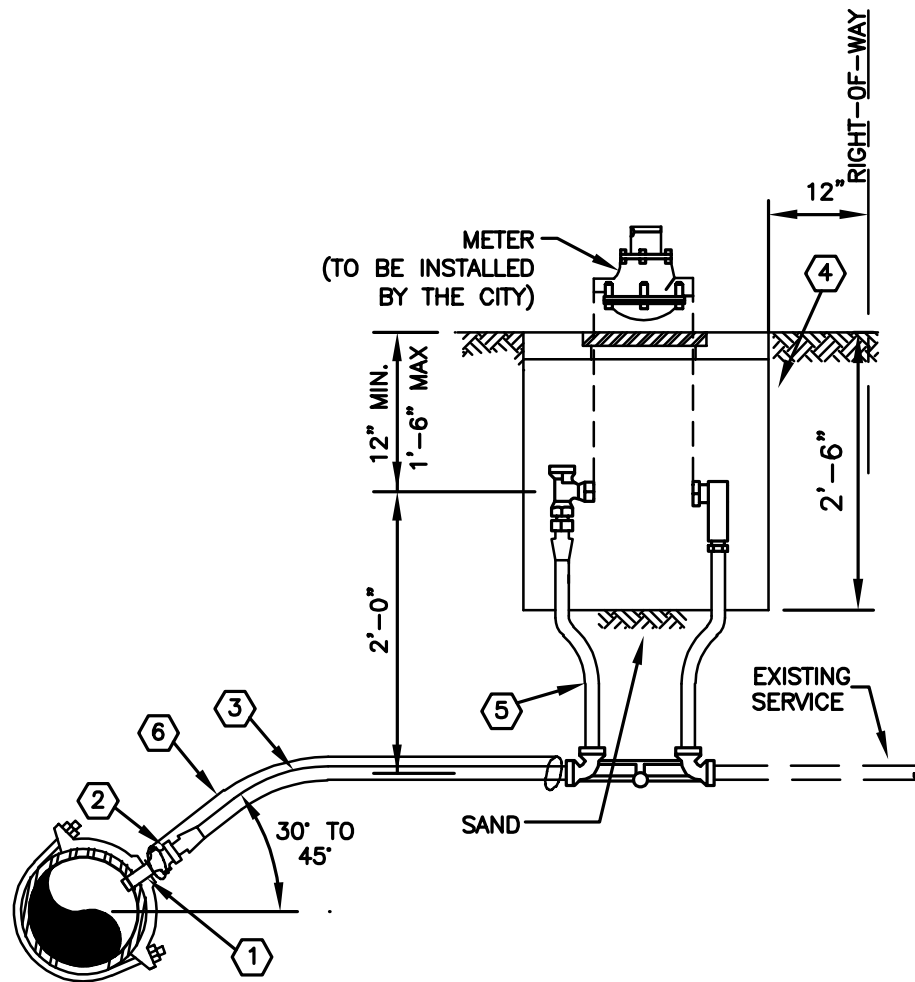

- ① FORD DOUBLE STRAP SERVICE SADDLE.
- ② CORPORATION STOP MUELLER H-15008.
- ③ 1" HDPE SERVICE PIPE – LENGTH AS REQUIRED(CTS 200PSI)
- ④ BROOKS 13" X 24" METER BOX WITH H-20 RATED CAST IRON COVER.
- ⑤ FORD 70 SERIES COPPERSETTER, WITH ANGLE BALL AND SINGLE CHECK VALVE OR APPROVED EQUAL.
- ⑥ 14 GAUGE TRACER WIRE.

NOTES:

1. SERVICE FROM METER BOX TO HOUSE BY PROPERTY OWNER.
2. INDIVIDUAL SERVICES REQUIRED FOR EACH LOT.
3. METER TO BE INSTALLED BY THE CITY AT OWNER'S EXPENSE.
4. COMPARABLE "FORD" FITTINGS MAY BE USED IN LIEU OF "MUELLER".



BRIDGEPORT
Washington State

FIGURE W-8
3/4" OR 1" WATER SERVICE

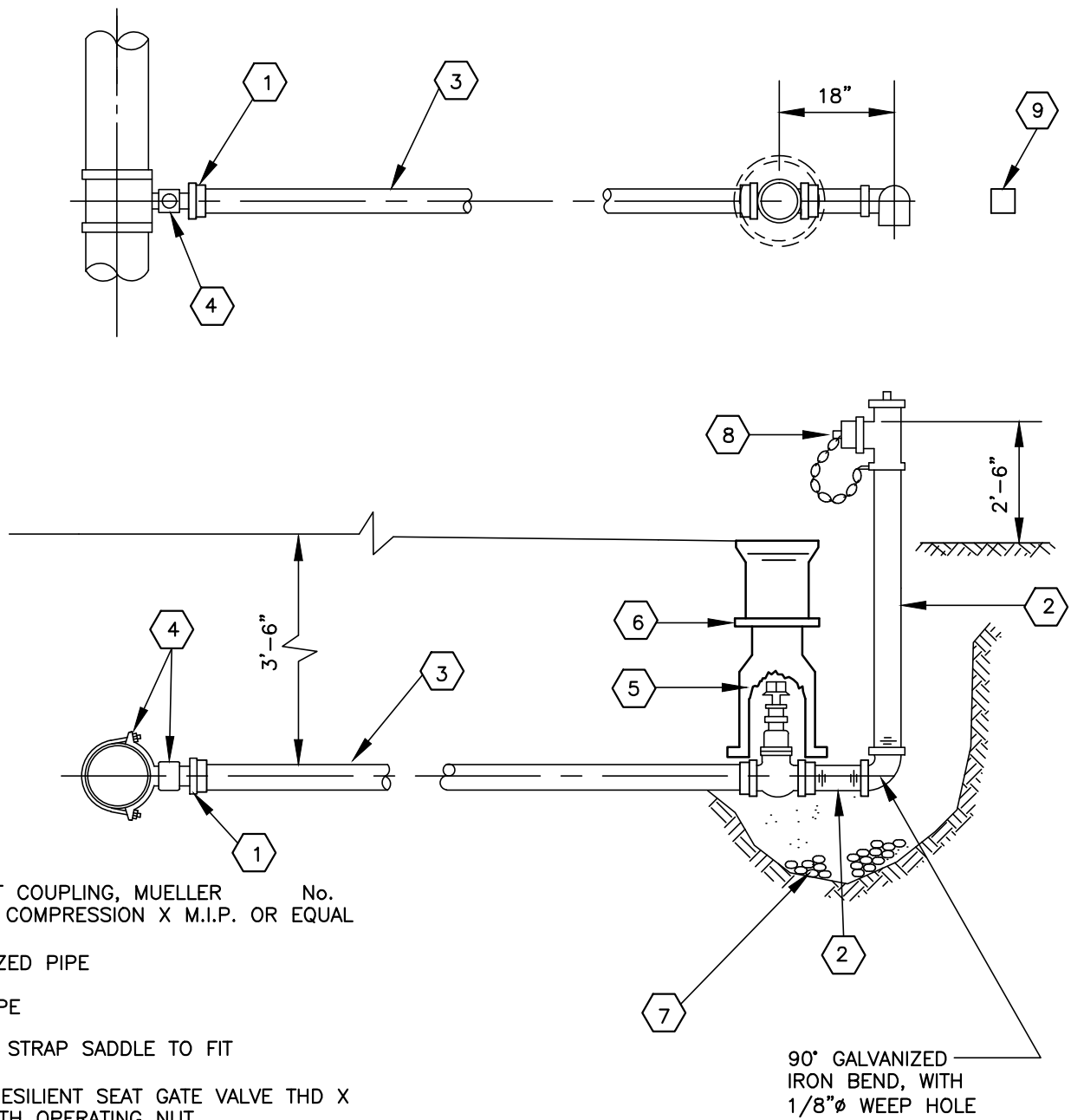

Gray & Osborne, Inc.



- 1 STRAIGHT COUPLING, MUELLER No. H15428 COMPRESSION X M.I.P. OR EQUAL
- 2 GALVANIZED PIPE
- 3 PVC PIPE
- 4 DOUBLE STRAP SADDLE TO FIT
- 5 AWWA RESILIENT SEAT GATE VALVE THD X THD, WITH OPERATING NUT.
- 6 CAST IRON VALVE BOX
- 7 1/4 CUBIC YARD WASHED GRAVEL POCKET.
- 8 FREEZE RESISTANT HYDRANT TRUFLO#TF200, OR EQUAL WITH 2-1/2" HOSE THREADS
- 9 VALVE MARKER POST

NOTES:

1. TURN NOZZLE TOWARDS ROADSIDE DITCH WHEN POSSIBLE
2. INSTALL DIELECTRIC COUPLINGS AT DISSIMILAR METALS.
3. BLOWOFFS SHALL BE SIZED TO PROVIDE 2.5fps VELOCITY IN MAIN LINE (2" MIN.).



BRIDGEPORT
Washington State

FIGURE W-10
BLOW OFF ASSEMBLY



REV:9/14

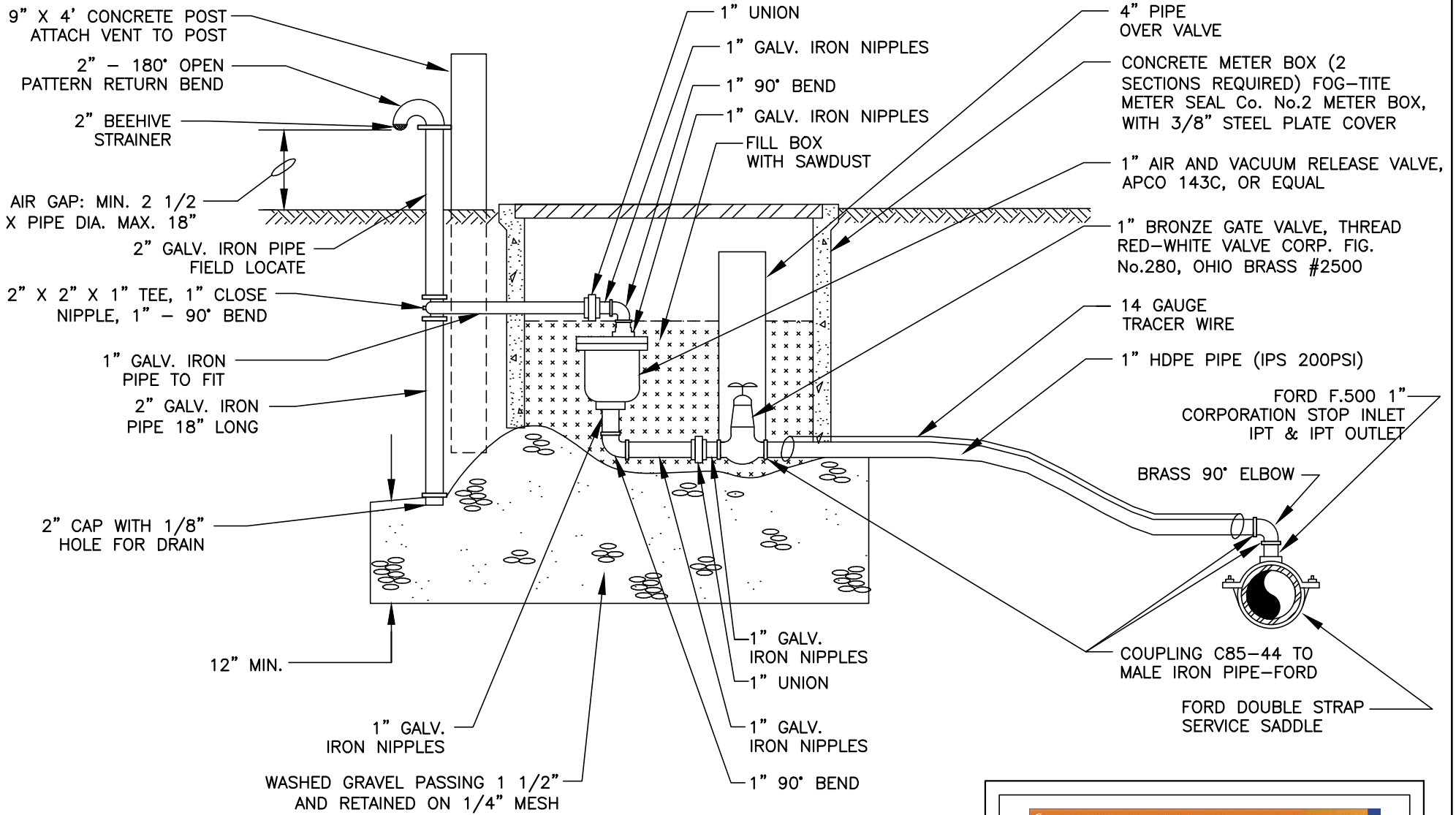

City of **BRIDGEPORT**
Washington State

FIGURE W-11
1" AIR AND VACUUM
RELEASE ASSEMBLY

Gray & Osborne, Inc.

REV:9/14

L:\BRIDGEPORT\14052 CONSTRUCTION STANDARDS\DEVELOPER STANDARDS\W-AIRVAC

SEWER DETAILS

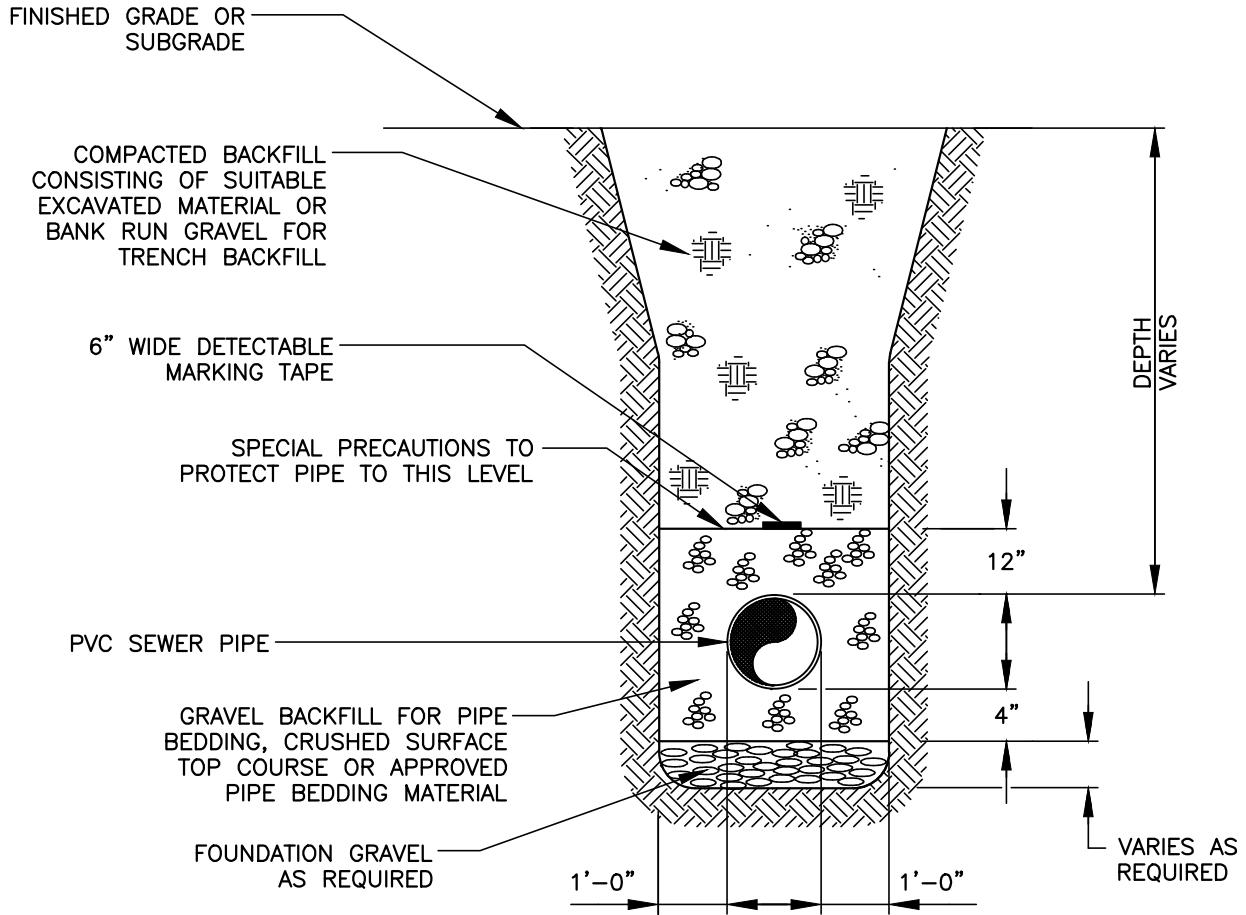

NOTES

1. ACTUAL SLOPE OF TRENCH SIDES TO BE DETERMINED BY CONTRACTOR TO FIT THE METHOD OF CONSTRUCTION AND ALL SAFETY REQUIREMENTS.

BRIDGEPORT
Washington State

DETAIL SS-1
SANITARY SEWER
TYPICAL TRENCH SECTION

Gray & Osborne, Inc.

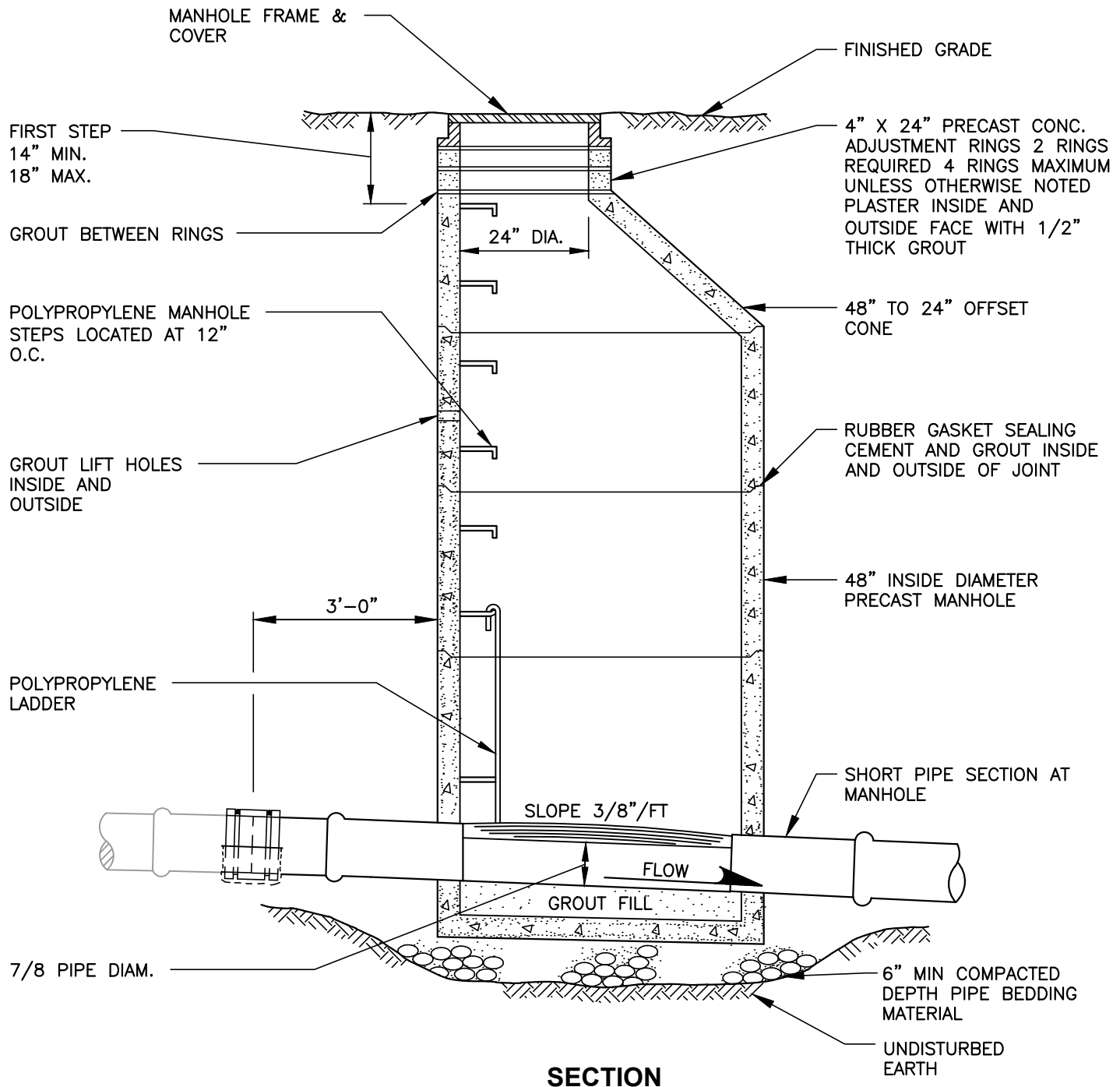

SECTION

NOTES

1. DROP OF GRADE THRU MANHOLE SHALL BE 0.10', UNLESS OTHERWISE NOTED.
2. MANHOLES SHALL BE SET PLUMB.
3. FOR CONNECTION OF EXISTING SEWER PIPE TO NEW MANHOLE, PROVIDE 3 LF OF PVC SEWER PIPE AND ROMAC 501 COUPLING, OR EQUAL.

L:\BRIDGEPORT\14022 CONSTRUCTION STANDARDS\DEVELOPER STANDARDS\SS-XX STANDARD 48 IN. MANHOLE

REV:9/14



BRIDGEPORT
Washington State

DETAIL SS-2
STANDARD 48" MANHOLE

Gray & Osborne, Inc.

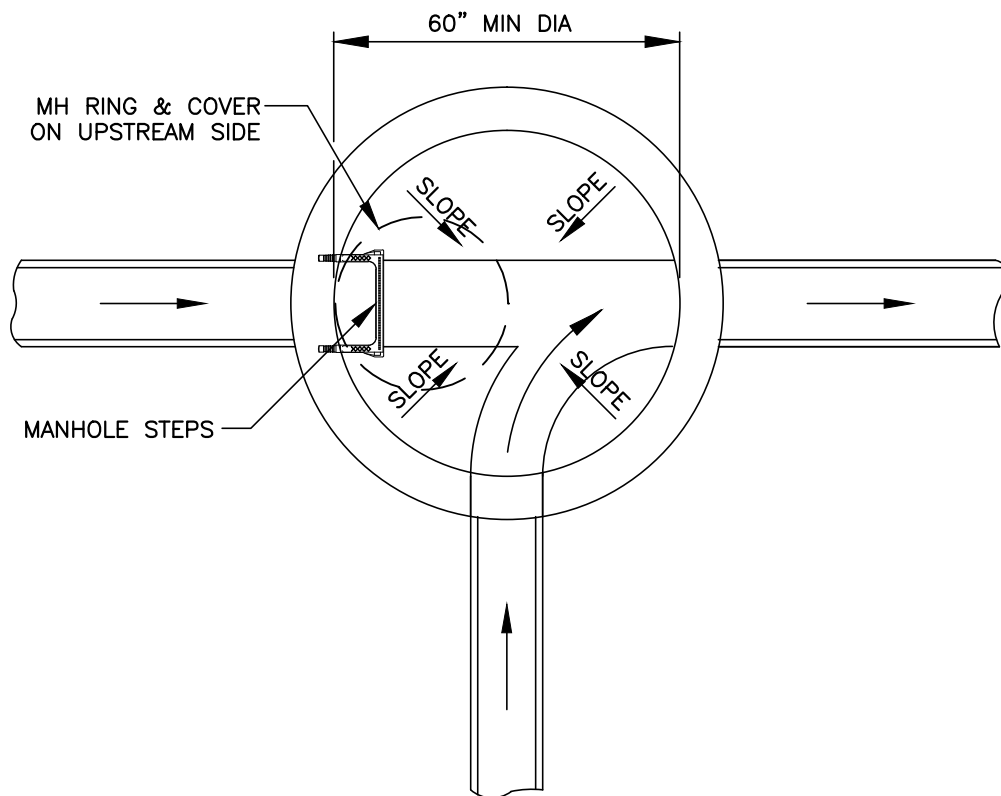

NOTE
 TRANSITION FROM MANHOLE BENCH TO CHANNEL SHALL BE ROUNDED WITH NO SHARP EDGES. PIPE PENETRATIONS AND CHANNELS SHALL PROVIDE A SMOOTH SURFACE THAT SHALL NOT RETAIN ANY WATER.



**DETAIL SS-3
 MANHOLE PLAN VIEW**



Gray & Osborne, Inc.

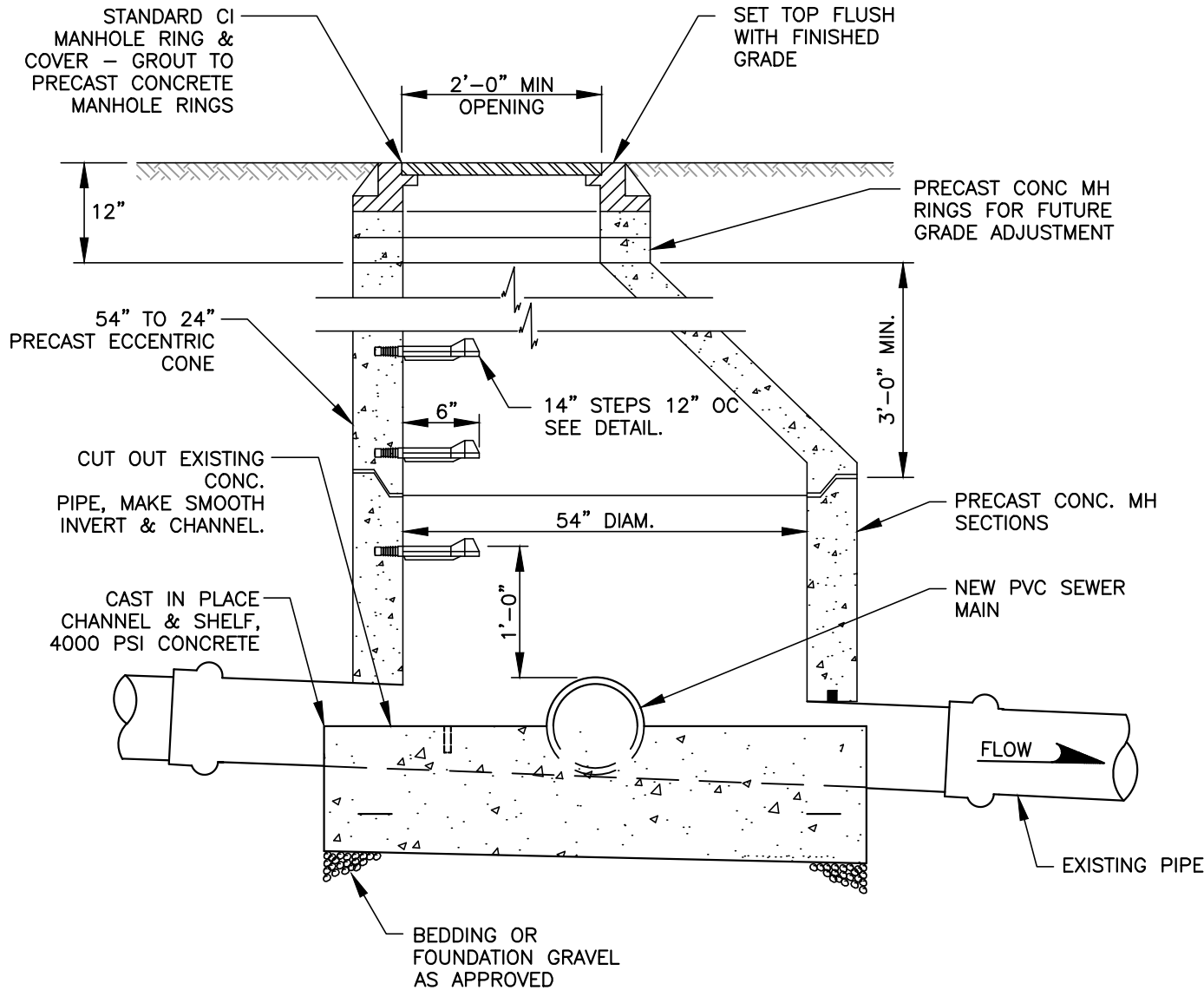

L:\BRIDGEPORT\4022 CONSTRUCTION STANDARDS\DEVELOPER STANDARDS\SS-XX SADDLE MANHOLE

REV:9/14

BRIDGEPORT
Washington State

DETAIL SS-4
SADDLE MANHOLE

Gray & Osborne, Inc.

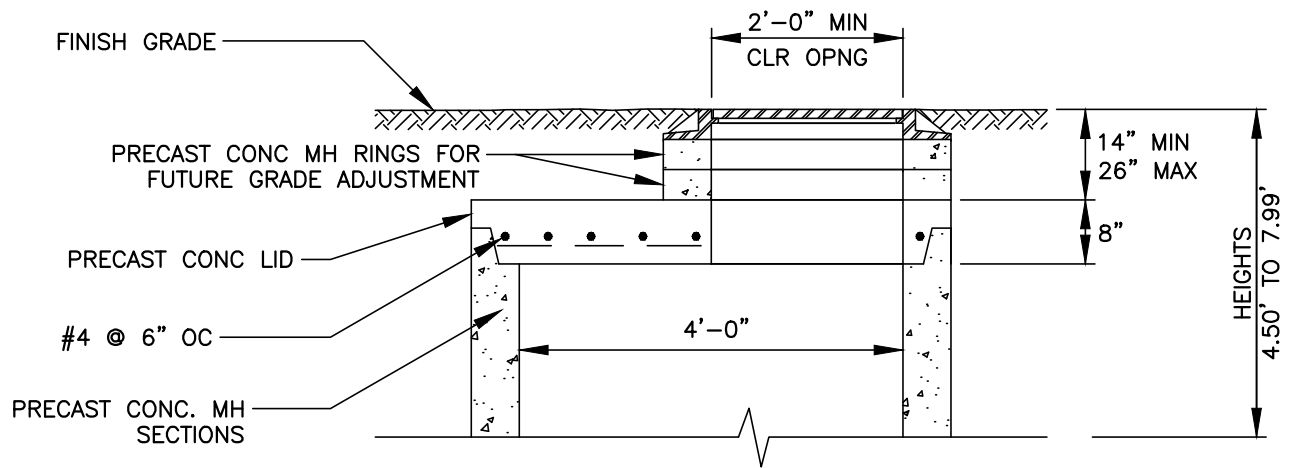

NOTE
 DETAILS OF MH BASE, WALL SECTIONS &
 STEPS IDENTICAL W/STANDARD MANHOLE
 DETAILS.

L:\BRIDGEPORT\4022 CONSTRUCTION STANDARDS\DEVELOPER STANDARDS\SS-XX SHALLOW MANHOLE

REV:9/14

BRIDGEPORT
 Washington State

DETAIL SS-5
 SHALLOW MANHOLE

Gray & Osborne, Inc.

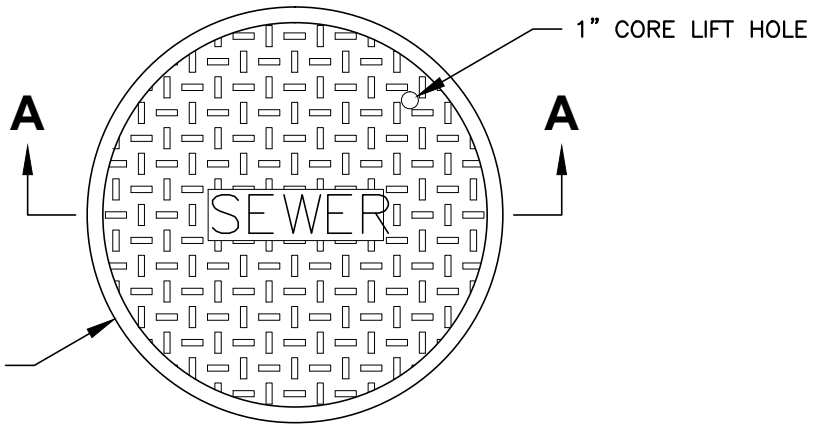

"SEWER" CAST ON COVER WITH
3" HIGH RAISED LETTERS
(NON-SKID PATTERN) AS
MANUFACTURED BY "SATHER
MANUFACTURING CO., INC." NO.
6024-R.

PLAN

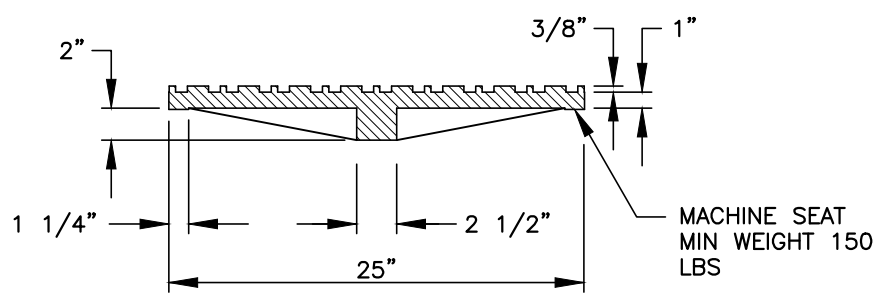

SECTION A-A

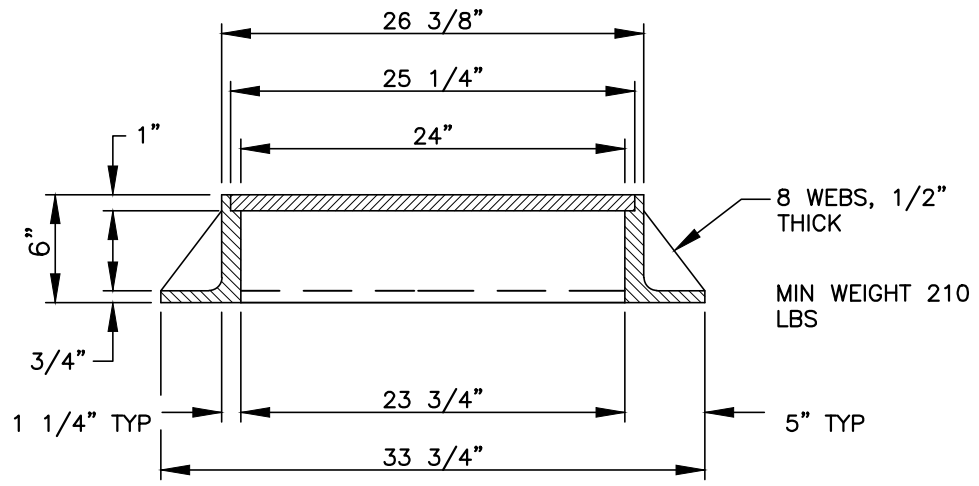

L:\BRIDGEPORT\14022 CONSTRUCTION STANDARDS\DEVELOPER STANDARDS\SS-XX STANDARD MANHOLE FRAME AND COVER

REV:9/14

DETAIL SS-6
STANDARD MANHOLE FRAME AND COVER

'MA INDUSTRIES, INC.'
 1/2" GRADE 60 STEEL
 REINFORCED COPOLYMER
 POLYPROPYLENE PLASTIC
 PS2-PF MANHOLE STEPS

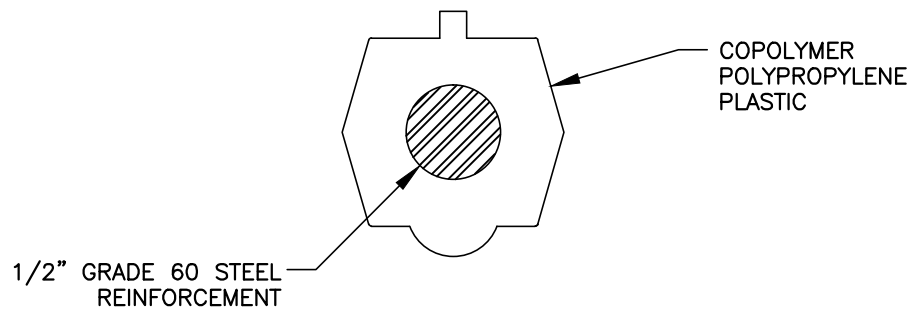
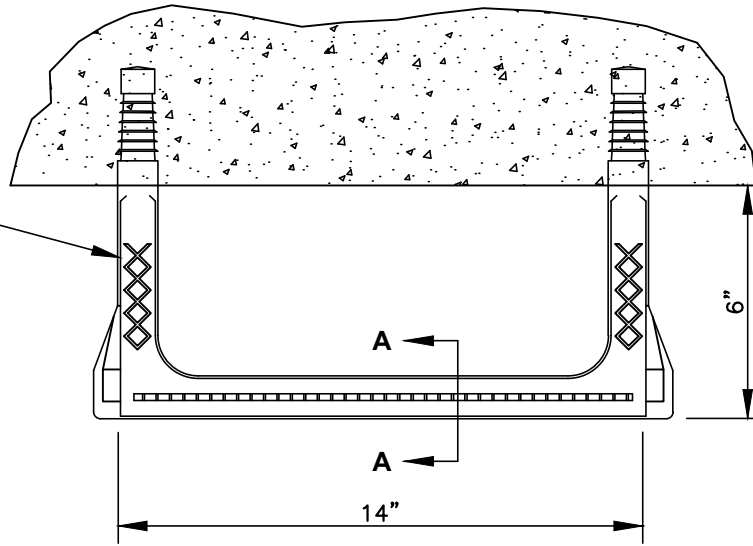

SECTION A-A

L:\BRIDGEPORT\4022 CONSTRUCTION STANDARDS\DEVELOPER STANDARDS\SS-XX MANHOLE STEP

REV:9/14



BRIDGEPORT
Washington State

DETAIL SS-7
 MANHOLE STEP



Gray & Osborne, Inc.

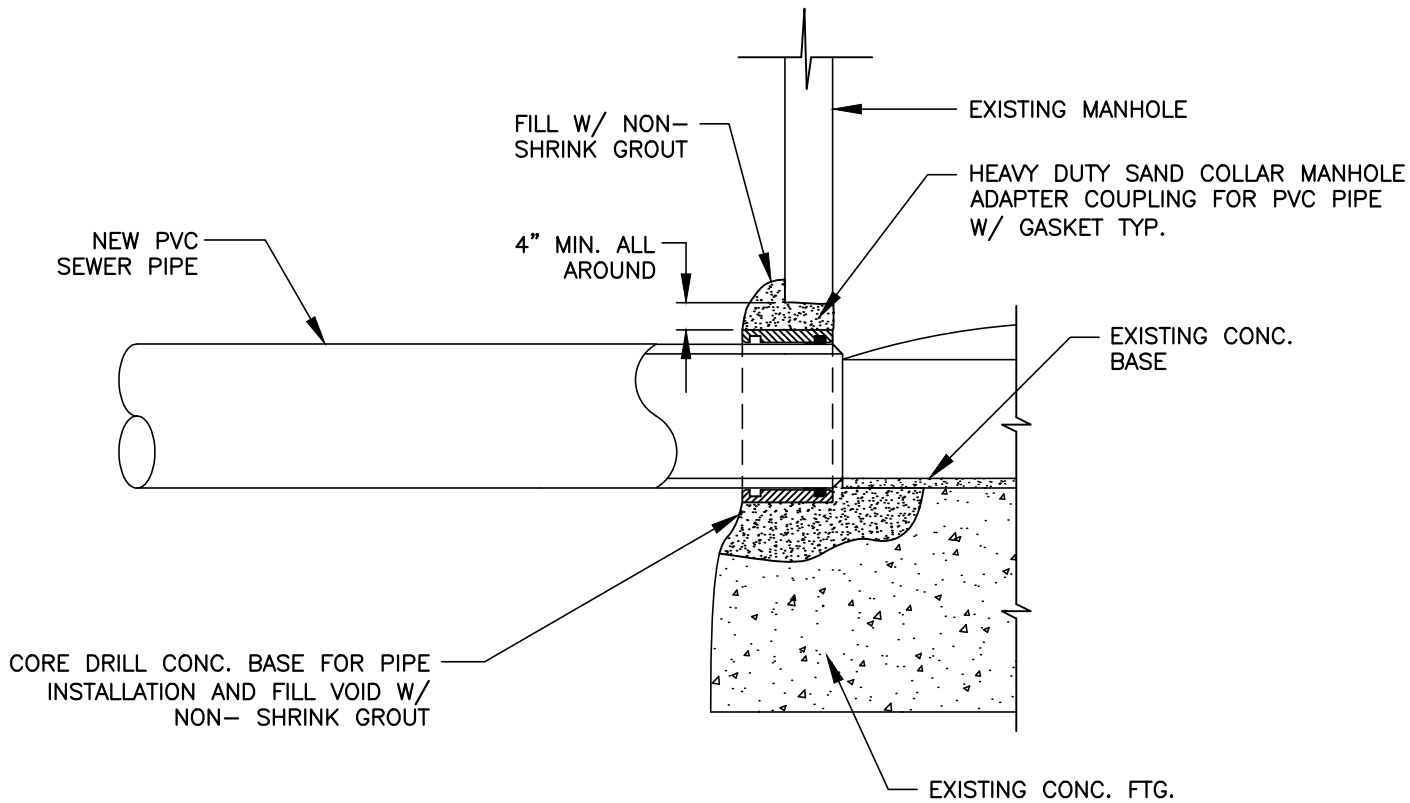

REV:9/14

BRIDGEPORT
Washington State

DETAIL SS-8
CONNECTION TO EXISTING
SANITARY SEWER MANHOLE

Gray & Osborne, Inc.

SEWER MAIN

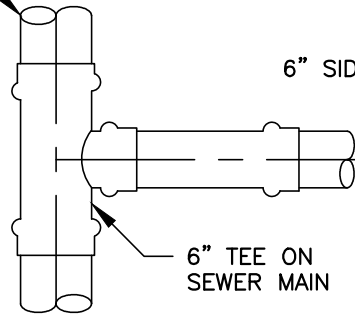

6" SIDE SEWER

6" TEE ON SEWER MAIN

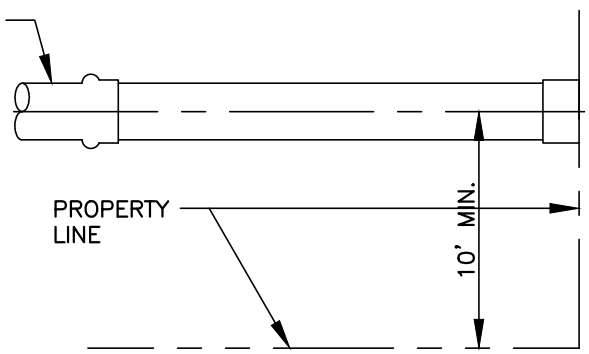

PROPERTY LINE

10' MIN.

PLAN

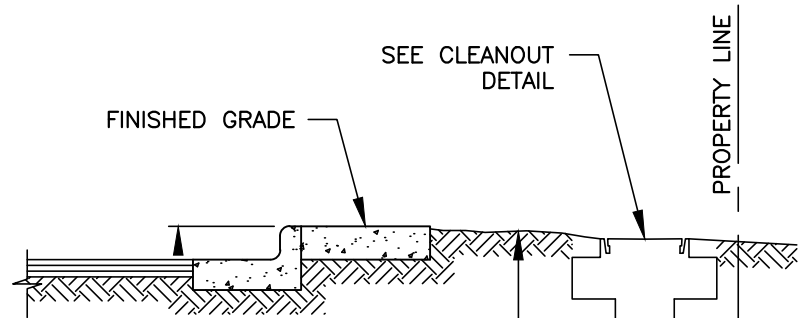

SEE CLEANOUT DETAIL

FINISHED GRADE

PROPERTY LINE

6'-0" MIN.

5'-0" MINIMUM VARIES

WATERTIGHT CAP
D.I.: MJ CAP
PVC: GASKETED CAP

6" SIDE SEWER

6" TEE ON SEWER MAIN OR ROMAC CB SEWER SADDLE

SEWER MAIN

45° MAXIMUM SLOPE
2% MINIMUM SLOPE

ELEVATION

NOTES

1. MAXIMUM DEFLECTION NOT TO EXCEED PIPE MANUFACTURER RECOMMENDATIONS.
2. SIDE SEWER LATERAL SHALL BE THE SAME MATERIAL AS THE MAIN LINE SEWER AND BEDDED THE SAME.
3. SEPARATE LATERAL REQUIRED FOR EACH LOT.

REV:9/14



DETAIL SS-9
STANDARD SIDE SEWER

Gray & Osborne, Inc.

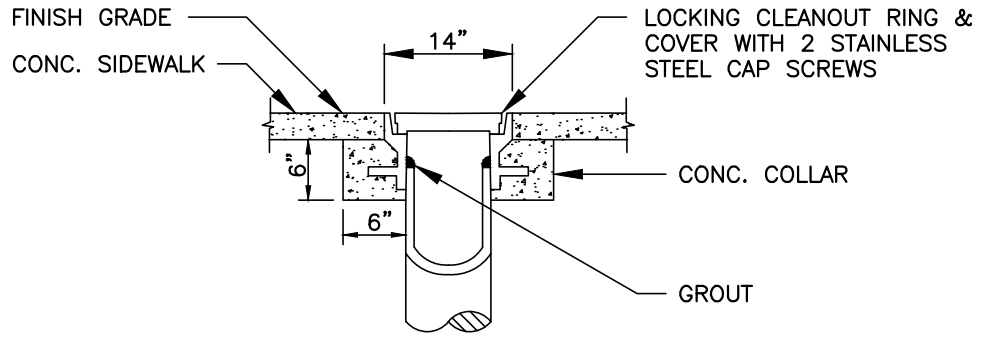

STREET USE

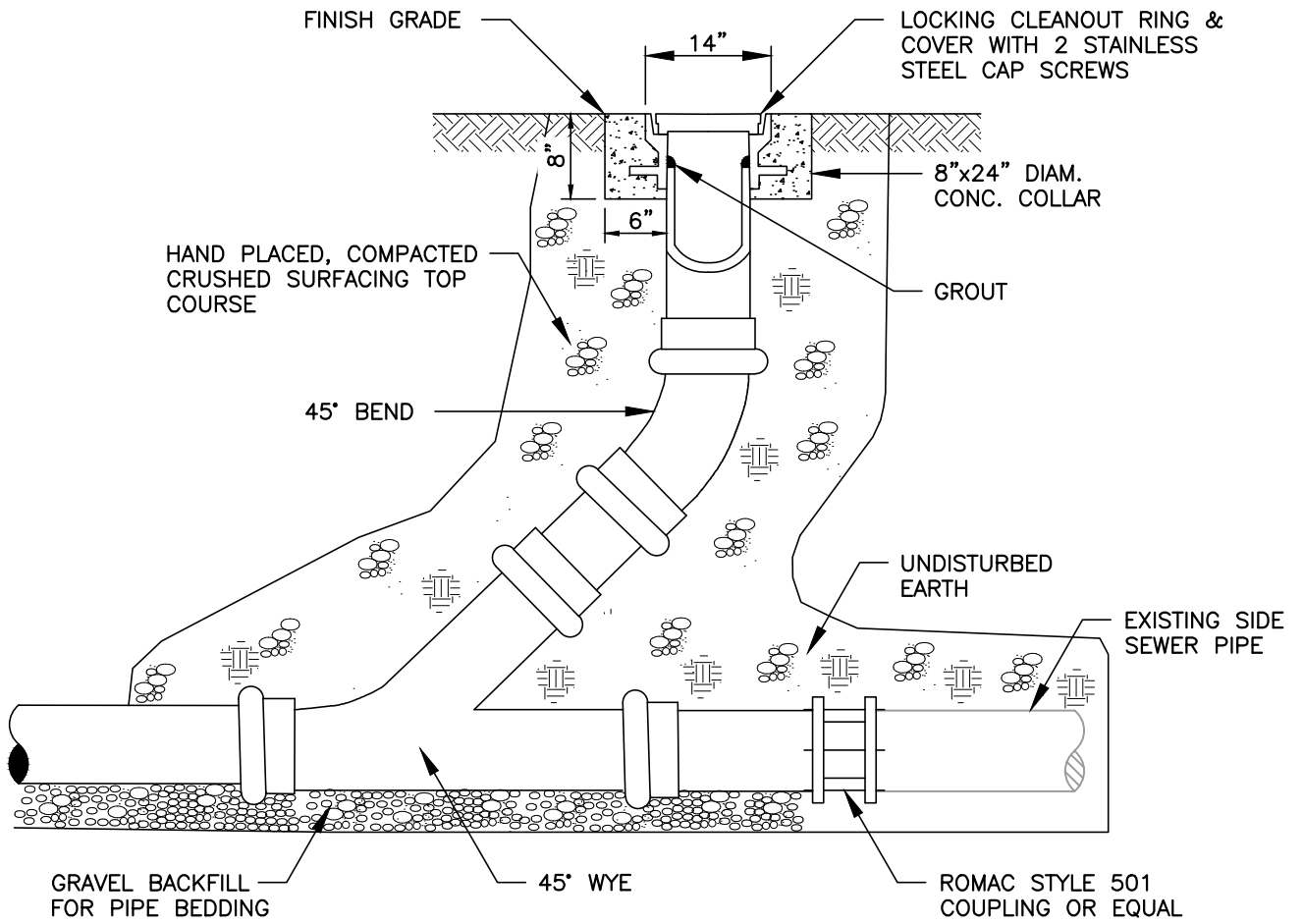

EASEMENT USE

L:\BRIDGEPORT\14022 CONSTRUCTION STANDARDS\DEVELOPER STANDARDS\SS-XX SANITARY SEWER CLEANOUT

REV:9/14



BRIDGEPORT
 Washington State

DETAIL SS-10
 SANITARY SEWER CLEANOUT



STREET DETAILS

L:\BRIDGEPORT\14052 CONSTRUCTION STANDARDS\DEVELOPER STANDARDS\CONC-TYP ROADWAY SECTION

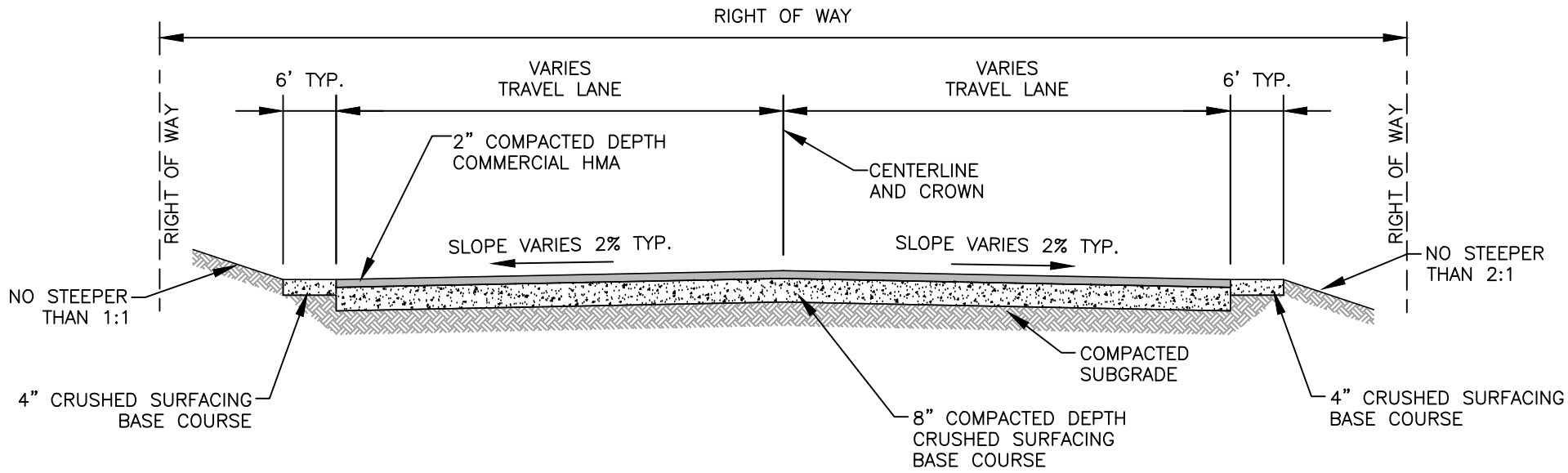

REV: 1/15



BRIDGEPORT
Washington State

DETAIL ST-1
TYPICAL ROADWAY SECTION



L:\BRIDGEPORT\14052 CONSTRUCTION STANDARDS\DEVELOPER STANDARDS\CONC-ALT ROADWAY SECTION

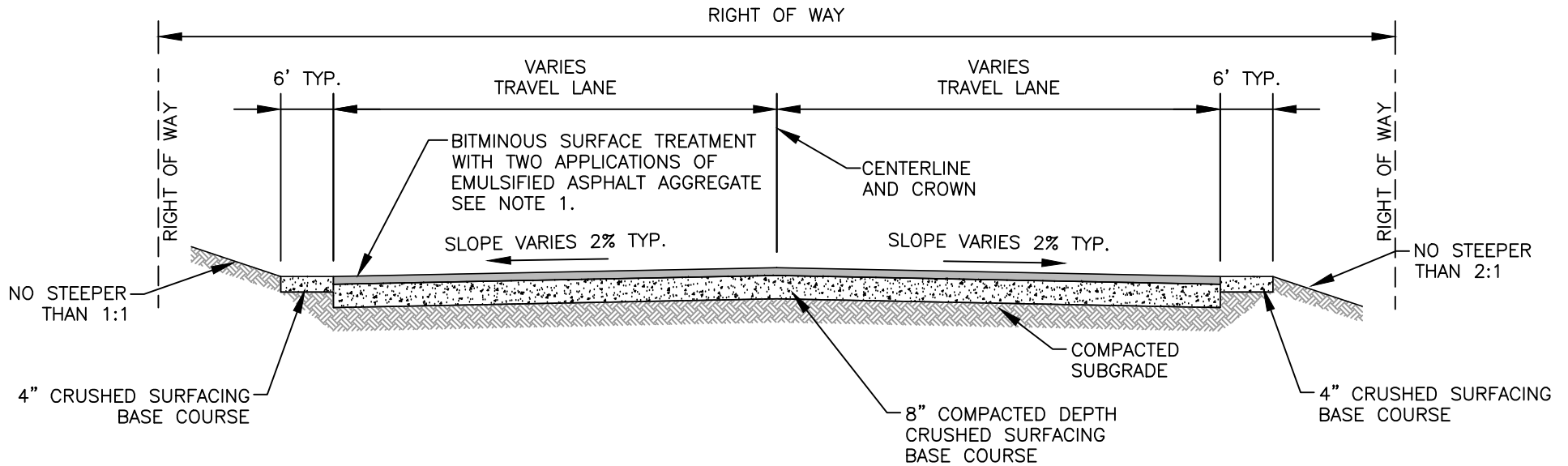

NOTES:

1.	APPLICATION RATE	EMULSIFIED ASPHALT (GAL/SY)	AGGREGATE SIZE	AGGREGATE APPLICATION RATE (#/SY)
	FIRST APPLICATION	0.50	½"–NO.4	40
	SECOND APPLICATION	.050	½"–NO.4	35

REV: 1/15



BRIDGEPORT
Washington State

DETAIL ST-2
ALTERNATE ROADWAY SECTION



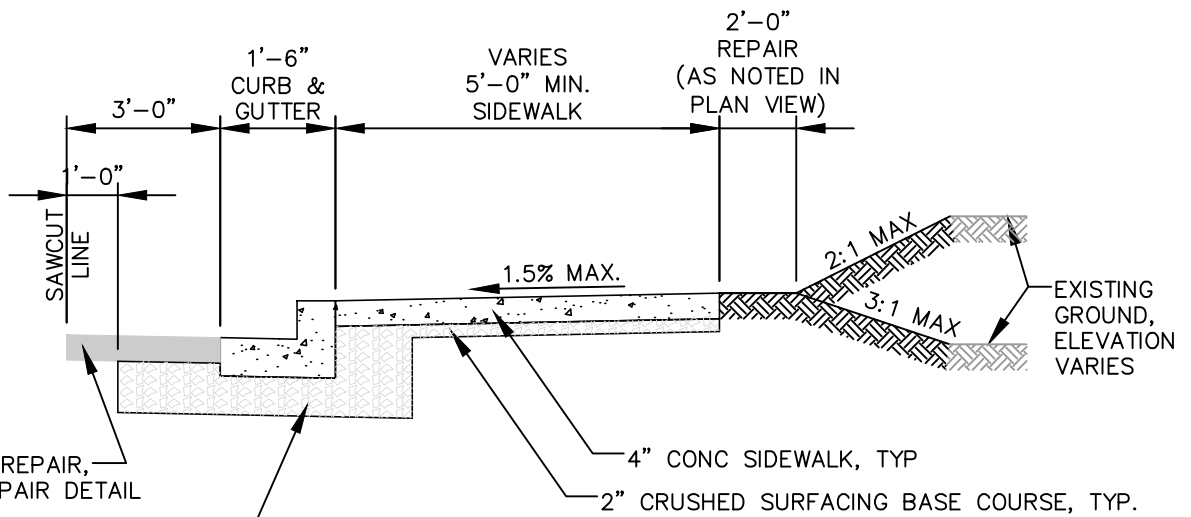

COMMERCIAL HMA REPAIR, SEE PAVEMENT REPAIR DETAIL

CRUSHED SURFACING BASE COURSE, SEE PAVEMENT REPAIR DETAIL & CEMENT CONCRETE TRAFFIC CURB & GUTTER DETAIL

4" CONC SIDEWALK, TYP
2" CRUSHED SURFACING BASE COURSE, TYP.

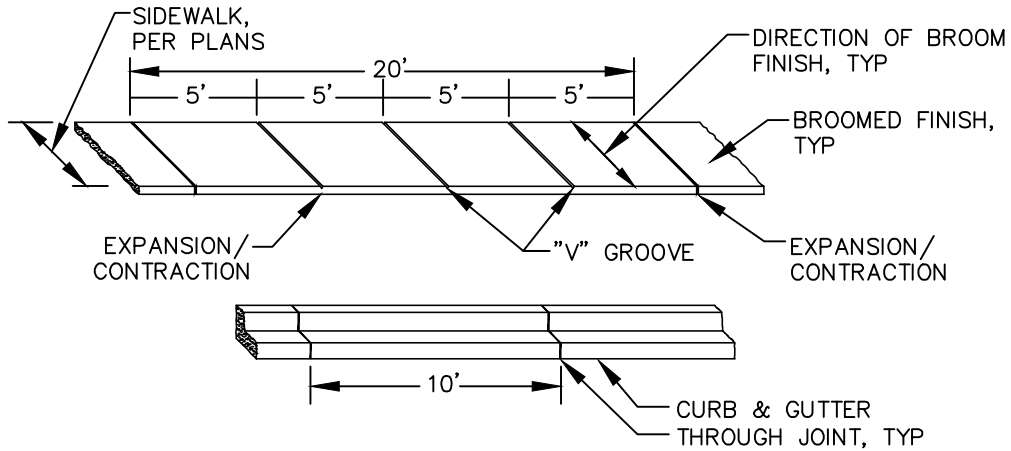

NOTES:

1. EXPANSION/CONTRACTION JOINTS SHALL BE 3/8" ASPHALT SATURATED FELT TO FULL DEPTH OF CONCRETE PLACED AT 15' O.C. AND AT POINTS OF TANGENCY ON CURVES, AT CATCH BASINS/INLETS, AND AT EDGES OF ALLEYS, DRIVEWAYS, AND CURB RAMPS.
2. V-GROOVE MARKS SHALL BE 1/8" DEEP AND 1/4" WIDE PLACED AT 5' OC FOR 5' SIDEWALKS.
3. ALL JOINTS SHALL BE CLEAN AND EDGED TO A 1/4" RADIUS. JOINTS SHALL BE FLUSH WITH THE FINISHED SURFACE.
4. SIDEWALK SHALL CONSIST OF 4" DEPTH CEMENT CONC. PLACED ON 2" COMPACTED DEPTH CRUSHED SURFACING BASE COURSE.
5. FOUR FEET OF THE SIDEWALK WIDTH SHALL BE THE MINIMUM PEDESTRIAN ACCESSIBLE ROUTE FREE OF VERTICAL AND HORIZONTAL OBSTRUCTIONS. GRATINGS, ACCESS COVERS, JUNCTION BOXES, CABLE VAULTS, PULL BOXES AND OTHER APPURTENANCES WITHIN THE SIDEWALK MUST HAVE SLIP RESISTANT SURFACES, BE FLUSH WITH SURFACE, AND MATCH GRADE OF THE SIDEWALK.

L:\BRIDGEPORT\14032 CONSTRUCTION STANDARDS\DEVELOPER STANDARDS\CONC-TYP SIDEWALK

REV: 1/15



BRIDGEPORT
Washington State

DETAIL ST-3
TYPICAL CONCRETE SIDEWALK

Gray & Osborne, Inc.

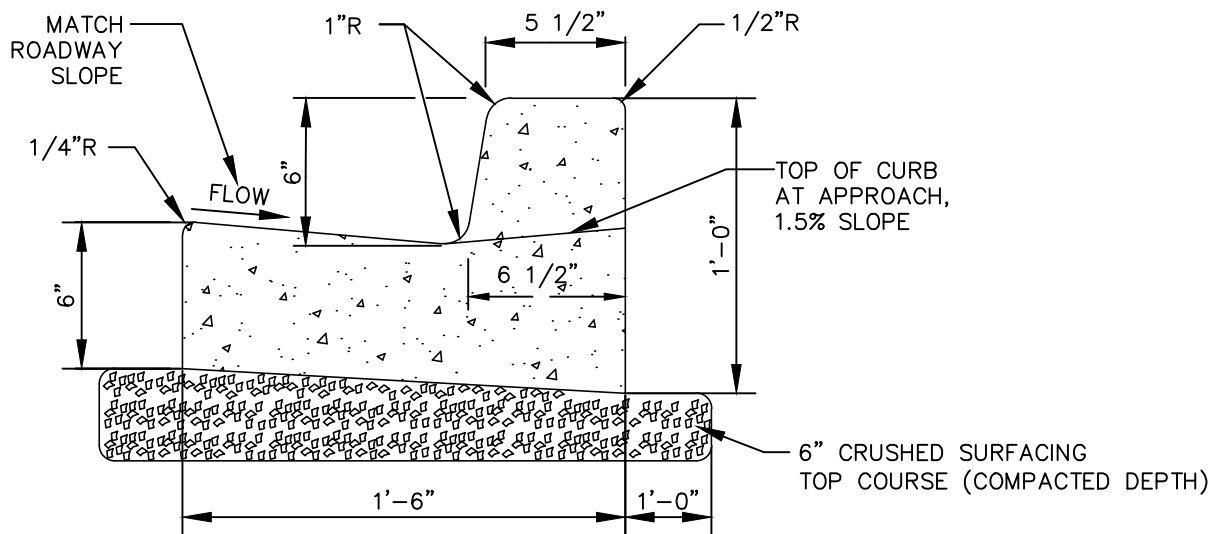

NOTES:

1. EXPANSION JOINT MATERIAL SHALL BE 3/8" THICK PREMOLDED JOINT FILLER FULL THICKNESS OF CONCRETE SPACING.
2. FORMS AND SUBGRADE INSPECTION AND APPROVAL BY THE CONTRACTING AGENCY REQUIRED PRIOR TO POURING CONCRETE.
3. THE TOP, FACE & GUTTER SHALL BE BROOM FINISHED PARALLEL TO THE ROADWAY.



BRIDGEPORT
Washington State

DETAIL ST-4
TYPICAL CURB AND GUTTER



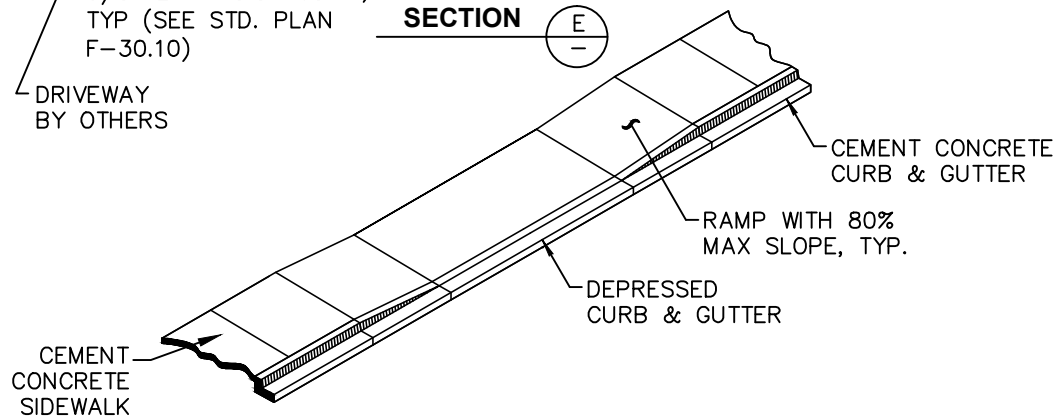
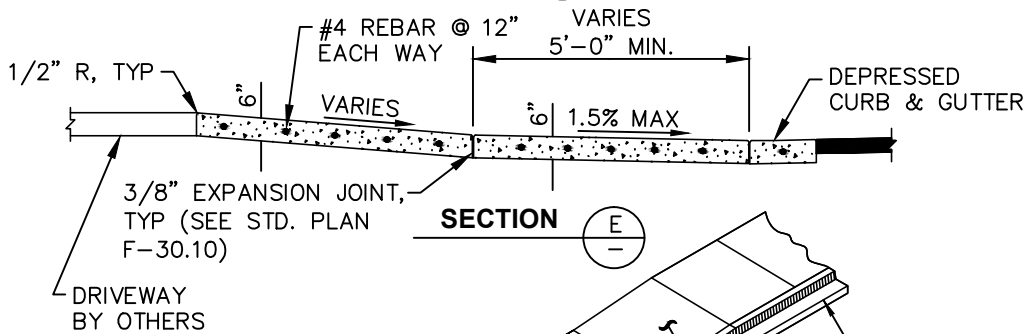
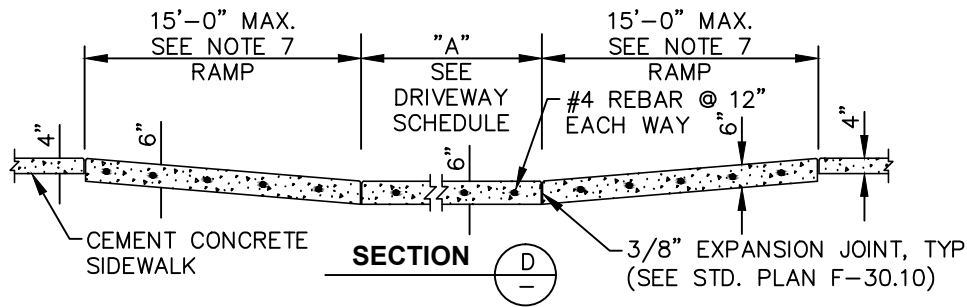
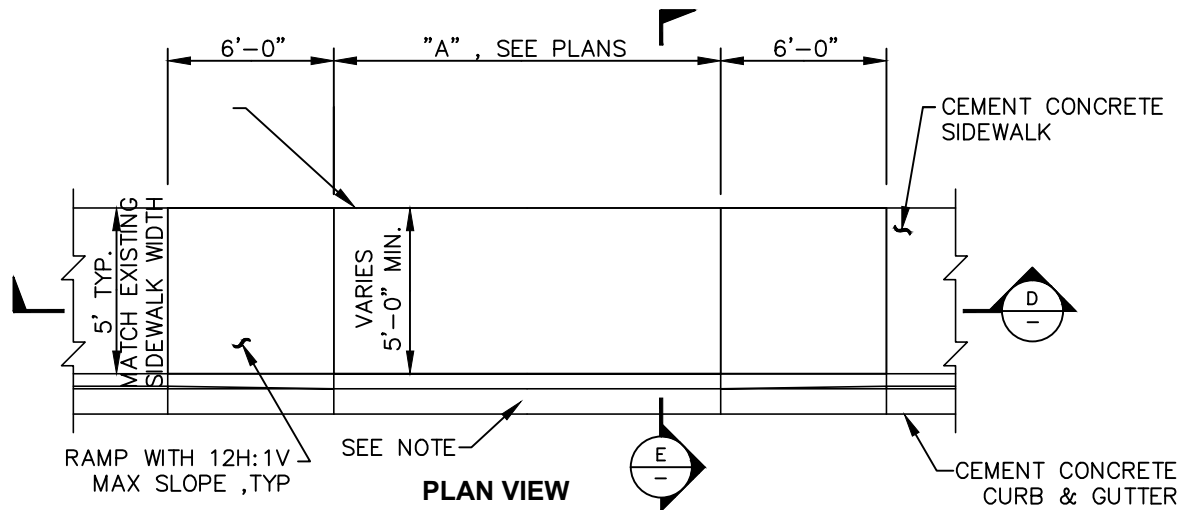

NOTES:

1. WHEN THE DRIVEWAY WIDTH EXCEEDS 10 FEET, CONSTRUCT A FULL DEPTH EXPANSION JOINT, SEE WSDOT STANDARD PLAN F-30.10 WITH 3/8" JOINT FILLER ALONG THE DRIVEWAY CENTERLINE. CONSTRUCT EXPANSION JOINTS PARALLEL WITH THE CENTERLINE AS REQUIRED AT 15' MAX SPACING WHEN DRIVEWAY WIDTHS EXCEED 30'.
2. COMPACT NATIVE MATERIAL TO 95%
3. 6" CEMENT CONCRETE CLASS 4000.
4. 2" CRUSHED SURFACING TOP BASE FOR BASE. CRUSHED SURFACING MATERIAL BENEATH CONCRETE DRIVEWAY NOT SHOWN FOR CLARITY.
5. CONCRETE DRIVEWAYS SHALL INCLUDE #4 REBAR AS SHOWN.
6. AVOID PLACING DRAINAGE STRUCTURES, JUNCTION BOXES OR OTHER OBSTRUCTIONS IN FRONT OF DRIVEWAY ENTRANCES.
7. THE CURB RAMP MAXIMUM RUNNING SLOPE SHALL NOT REQUIRE THE RAMP LENGTH TO EXCEED 15' (FT) TO AVOID CHASING THE SLOPE INDEFINITELY WHEN CONNECTING TO STEEP GRADES. WHEN APPLYING THE 15' (FT) MAX. LENGTH, THE RUNNING SLOPE OF THE CURB RAMP SHALL BE AS FLAT AS FEASIBLE.

REV: 1/15

BRIDGEPORT
Washington State

DETAIL ST-5
CONCRETE DRIVEWAY ENTRANCE

Gray & Osborne, Inc.

L:\BRIDGEPORT\14052 CONSTRUCTION STANDARDS\DEVELOPER STANDARDS\CONC-SIDEWALK RAMPS

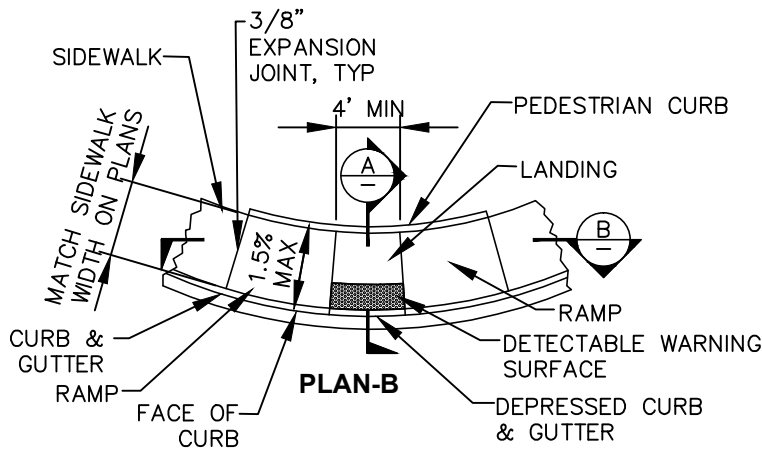

PARALLEL CURB RAMP

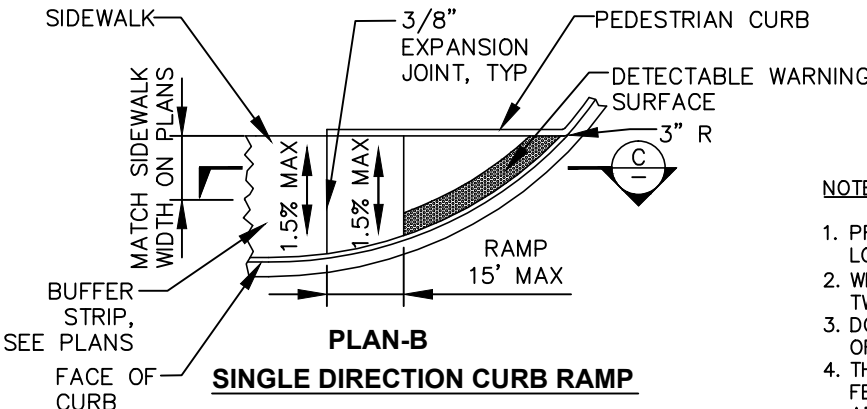

SINGLE DIRECTION CURB RAMP

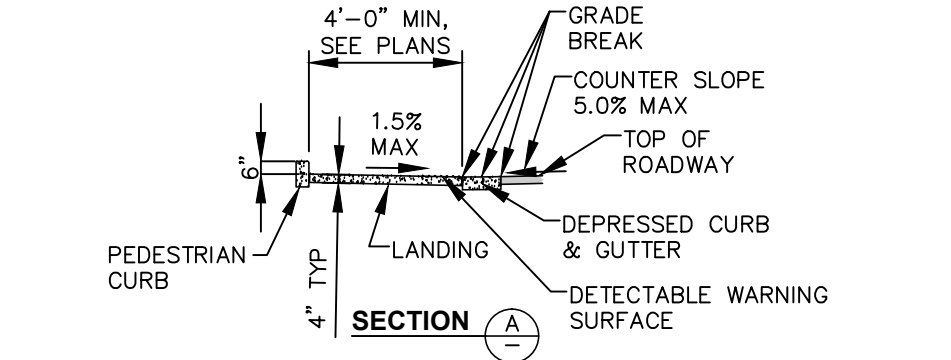

SECTION A

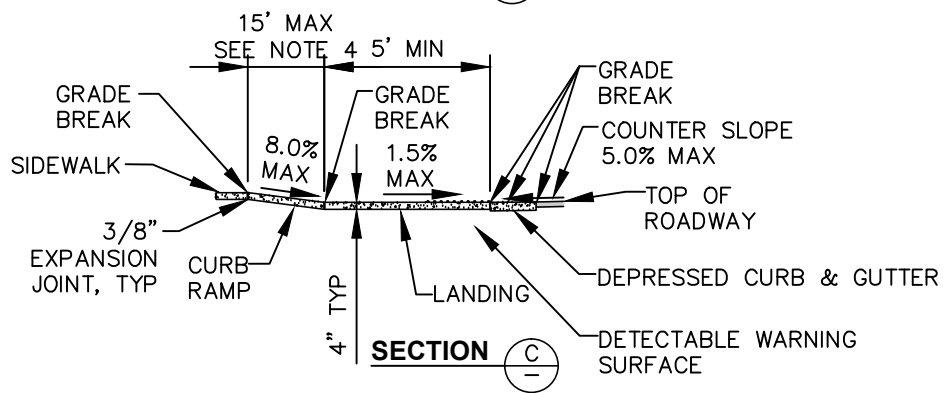

SECTION C

NOTES:

1. PROVIDE A SEPARATE CURB RAMP FOR EACH MARKED OR UNMARKED CROSSWALK. CURB RAMP LOCATION SHALL BE PLACED WITHIN THE WIDTH OF THE ASSOCIATED CROSSWALK.
2. WHERE "GRADE BREAK" IS CALLED OUT, THE ENTIRE LENGTH OF THE GRADE BREAK BETWEEN THE TWO ADJACENT SURFACE PLANES SHALL BE FLUSH.
3. DO NOT PLACE GRATINGS, JUNCTION BOXES, ACCESS COVERS, OR OTHER APPURTENANCES IN FRONT OF THE CURB RAMP OR ON ANY PART OF THE CURB RAMP OR LANDING.
4. THE CURB RAMP MAXIMUM RUNNING SLOPE SHALL NOT REQUIRE THE RAMP LENGTH TO EXCEED 15 FEET TO AVOID CHASING THE SLOPE INDEFINITELY WHEN CONNECTING TO STEEP GRADES. WHEN APPLYING THE 15 FOOT MAX LENGTH, THE RUNNING SLOPE OF THE CURB RAMP SHALL BE AS FLAT AS FEASIBLE.
5. CURB RAMP, LANDING, & FLARES SHALL RECEIVE BROOM FINISH.

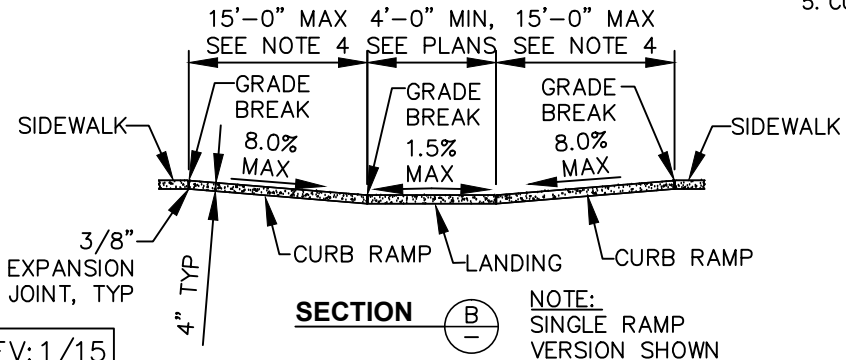

SECTION B

NOTE:
SINGLE RAMP
VERSION SHOWN

REV: 1/15

City of **BRIDGEPORT**
Washington State

DETAIL ST-6
SIDEWALK RAMPS

Gray & Osborne, Inc.

	MIN	MAX
A	1.60"	2.40"
B	0.65"	—
C	0.45"	0.90"
D	0.9"	1.40"
E	0.2"	0.2"

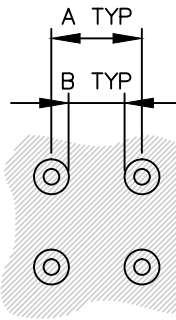

PLAN

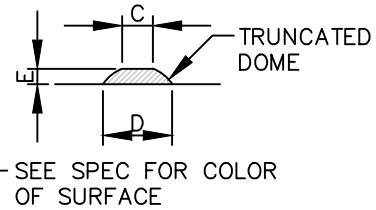

ELEVATION

NOTES:

1. THE DETECTABLE WARNING SURFACE SHALL EXTEND THE FULL WIDTH OF THE CURB RAMP (EXCLUSIVE OF FLARES) OR THE LANDING.
2. THE EDGE OF THE DETECTABLE WARNING SURFACE SHALL BE PLACED ALONG THE BACK OF THE CURB LINE.
3. THE ROWS OF TRUNCATED DOMES SHALL BE ALIGNED TO BE PERPENDICULAR TO THE GRADE BREAK AT THE BACK OF CURB.
4. SEE STANDARD PLANS FOR SIDEWALK AND CURB RAMP DETAILS.
5. IF A CURB IS NOT PRESENT, PLACE THE DETECTABLE WARNING SURFACE AT THE EDGE OF THE PAVEMENT.
6. IF A CURB RAMP IS REQUIRED, THE LOCATION OF THE DETECTABLE WARNING SURFACE MUST BE AT THE BOTTOM OF THE RAMP AND WITHIN THE REQUIRED DISTANCE FROM RAIL. SEE WSDOT STANDARD PLAN F-45.10



DETAIL ST-7
DETECTABLE WARNING SURFACE



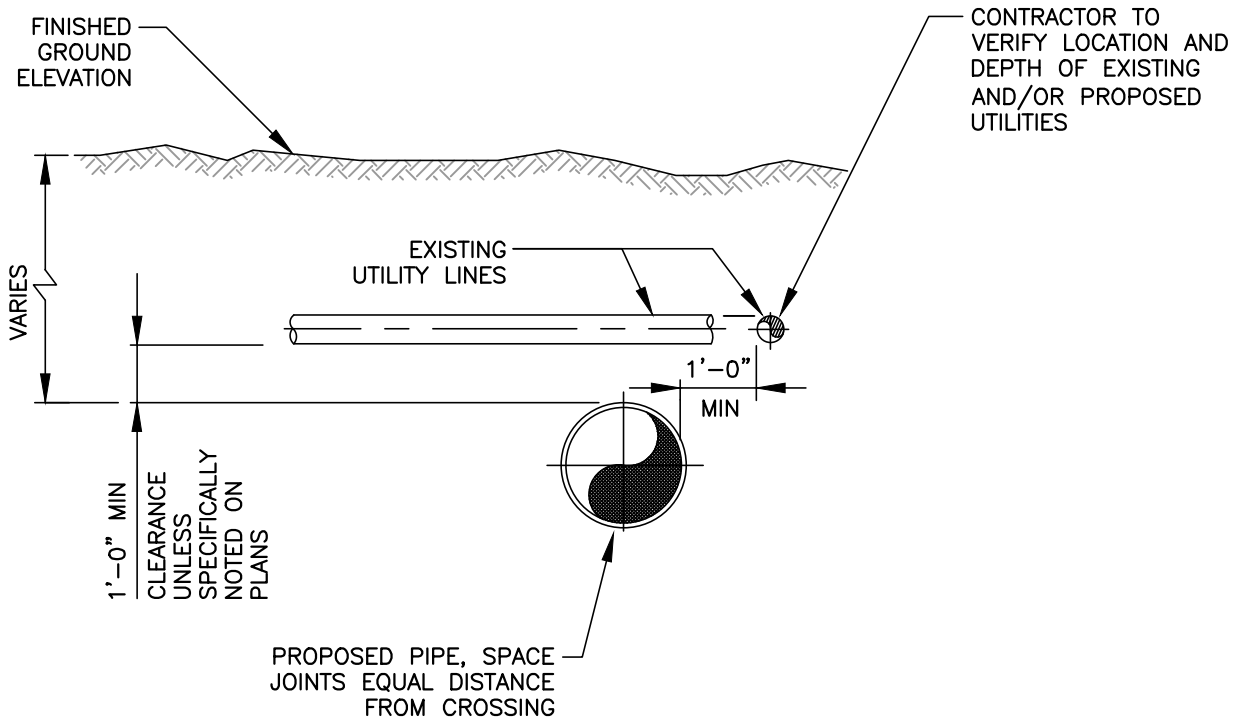

REV:9/14

BRIDGEPORT
Washington State

DETAIL ST-8
TYPICAL UTILITY CROSSING

Gray & Osborne, Inc.

